

- CZ** NÁVOD K MONTÁŽI
- EN** ASSEMBLY INSTRUCTIONS
- DE** MONTAGEANLEITUNG
- ES** INSTRUCCIONES DE MONTAJE
- NL** MONTAGEVOORSCHRIFT
- IT** ISTRUZIONI DI MONTAGGIO
- PT** INSTRUÇÕES DE MONTAGEM
- PL** INSTRUKCJA MONTAŻU
- CR** NAPUTCI ZA MONTAŽU

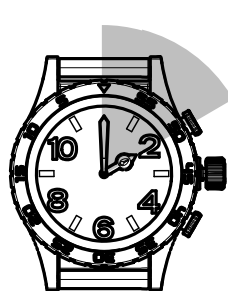

**2 h**

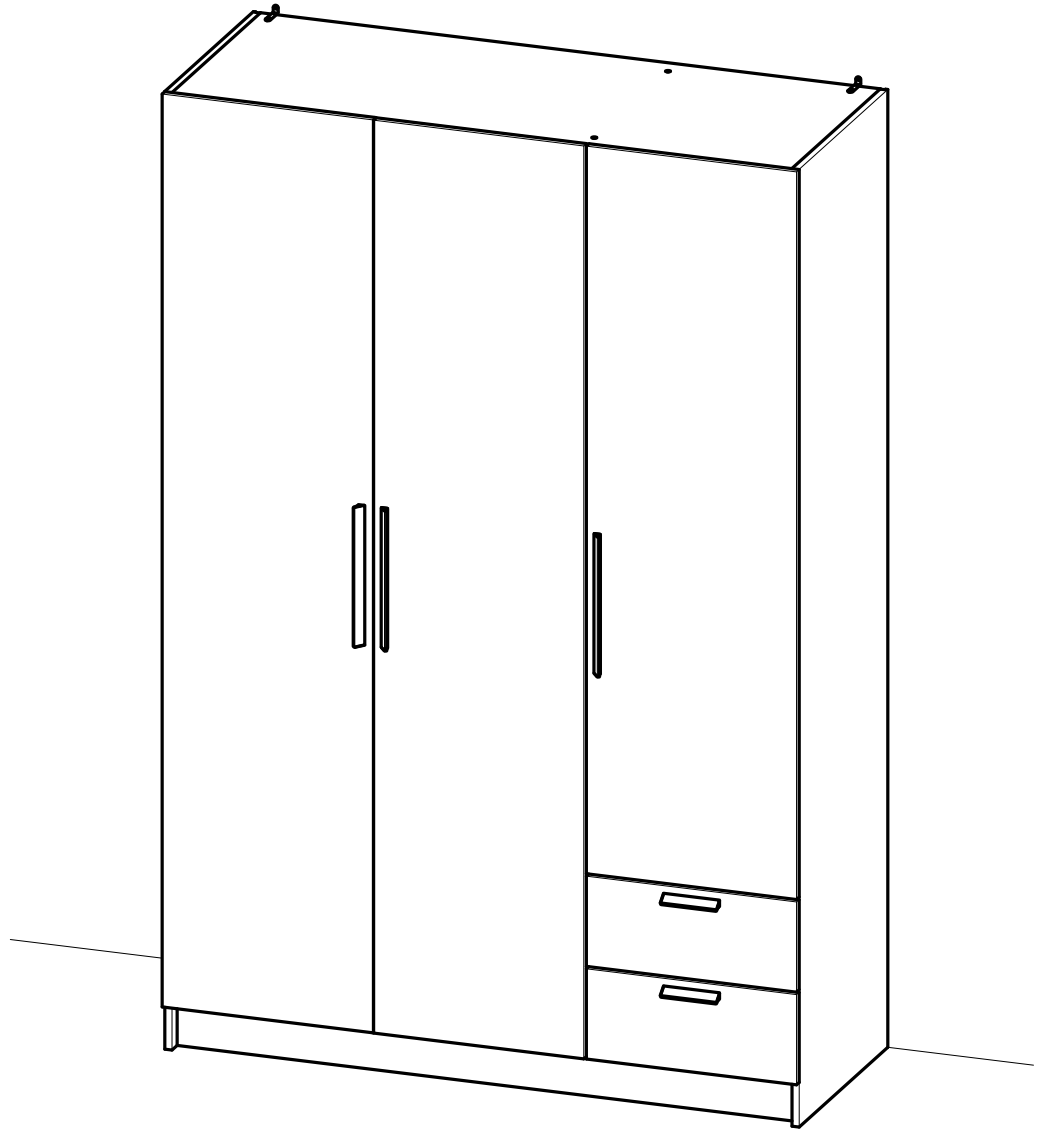
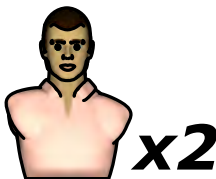

**x2**



Fabriqu  en France  
Made in France

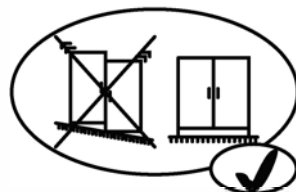
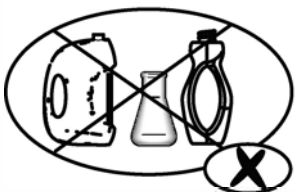
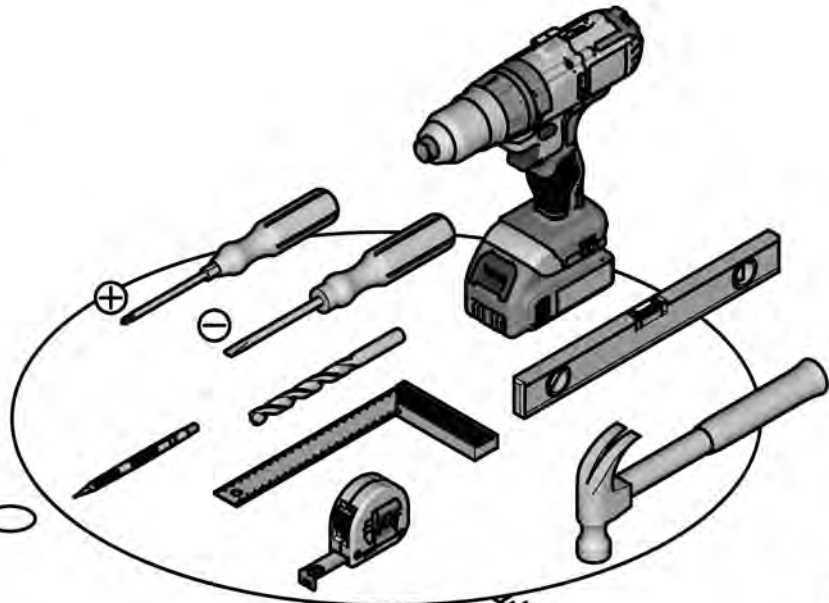
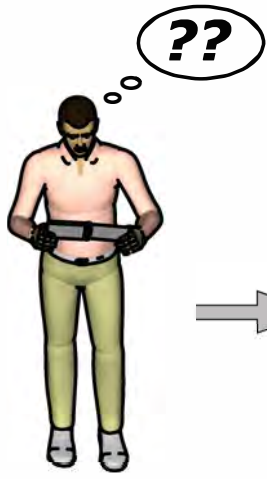



**A** x26

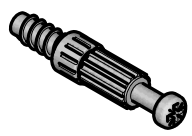

**K** x12

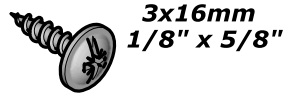

**B** x22



**L** x2

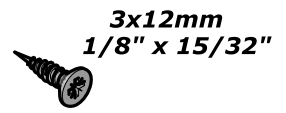

**C** x1

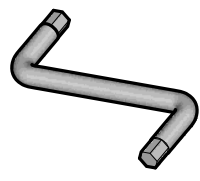

**M** x28

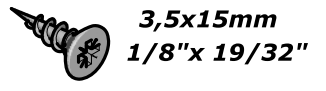

**D** x2

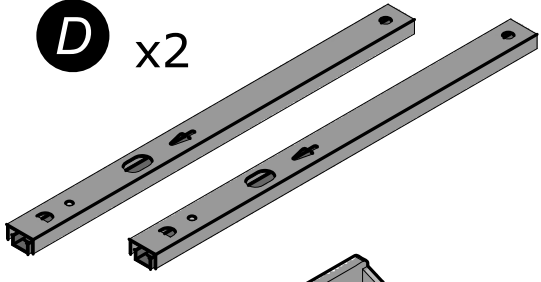

**N** x4

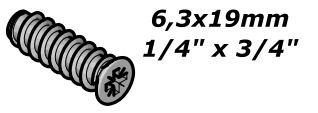

**E** x2

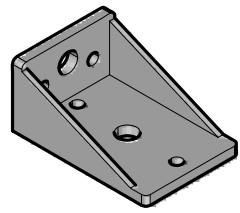

**O** x4

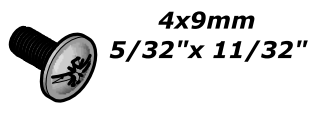

**F** x2

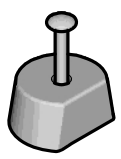

**P** x5

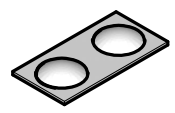

**G** x22

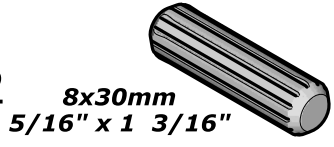

**Q** x1

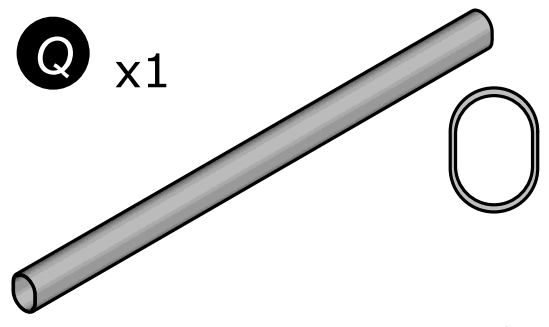

**H** x4

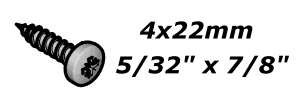

**R** x3

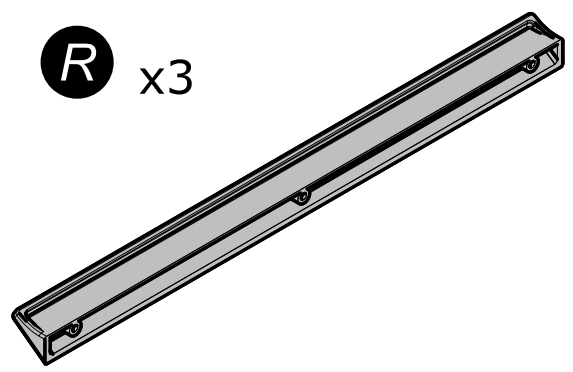

**I** x9

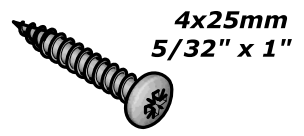

**J** x4

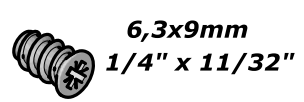

**S** x2

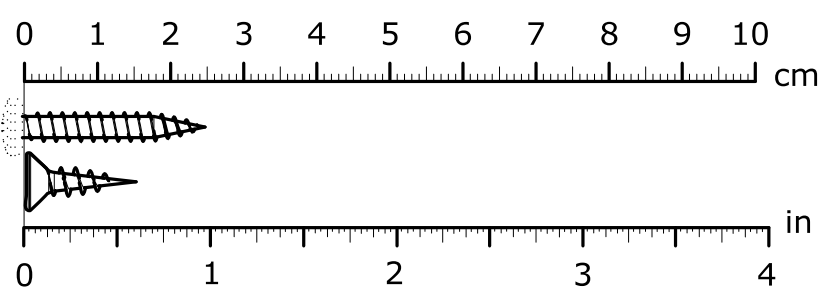
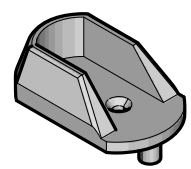

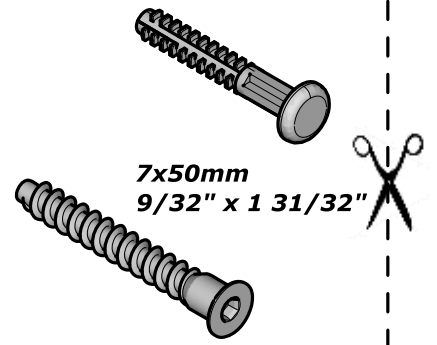
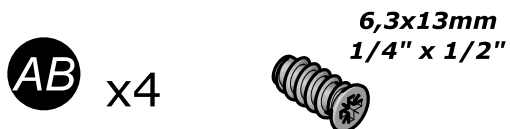
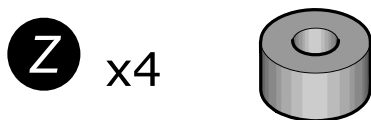
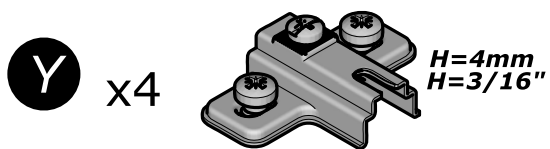
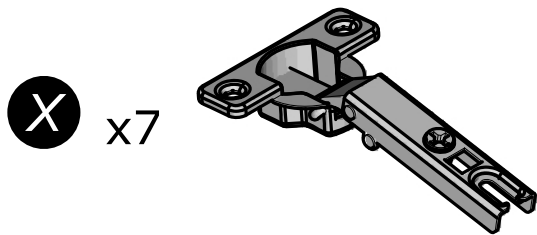
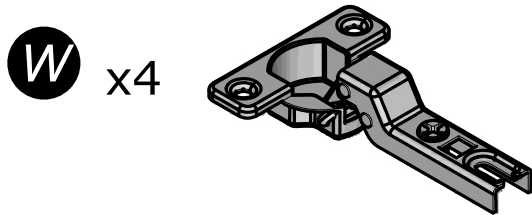
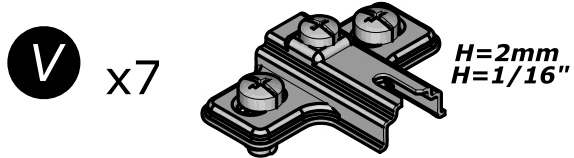
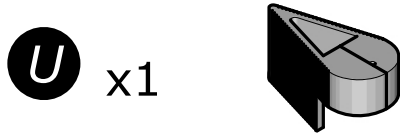
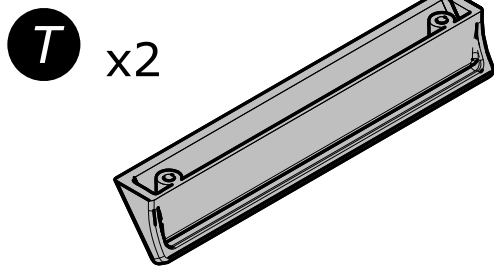

7x50mm  
9/32" x 1 31/32"

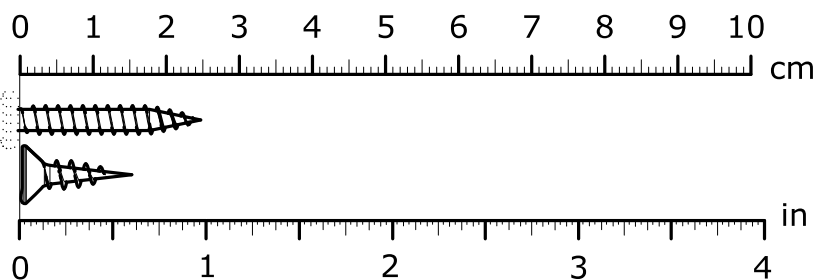
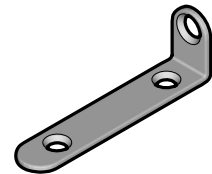
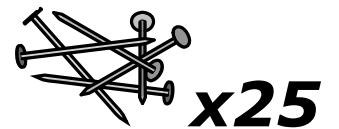
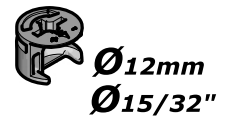
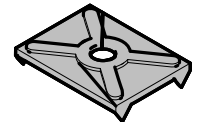
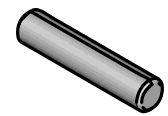

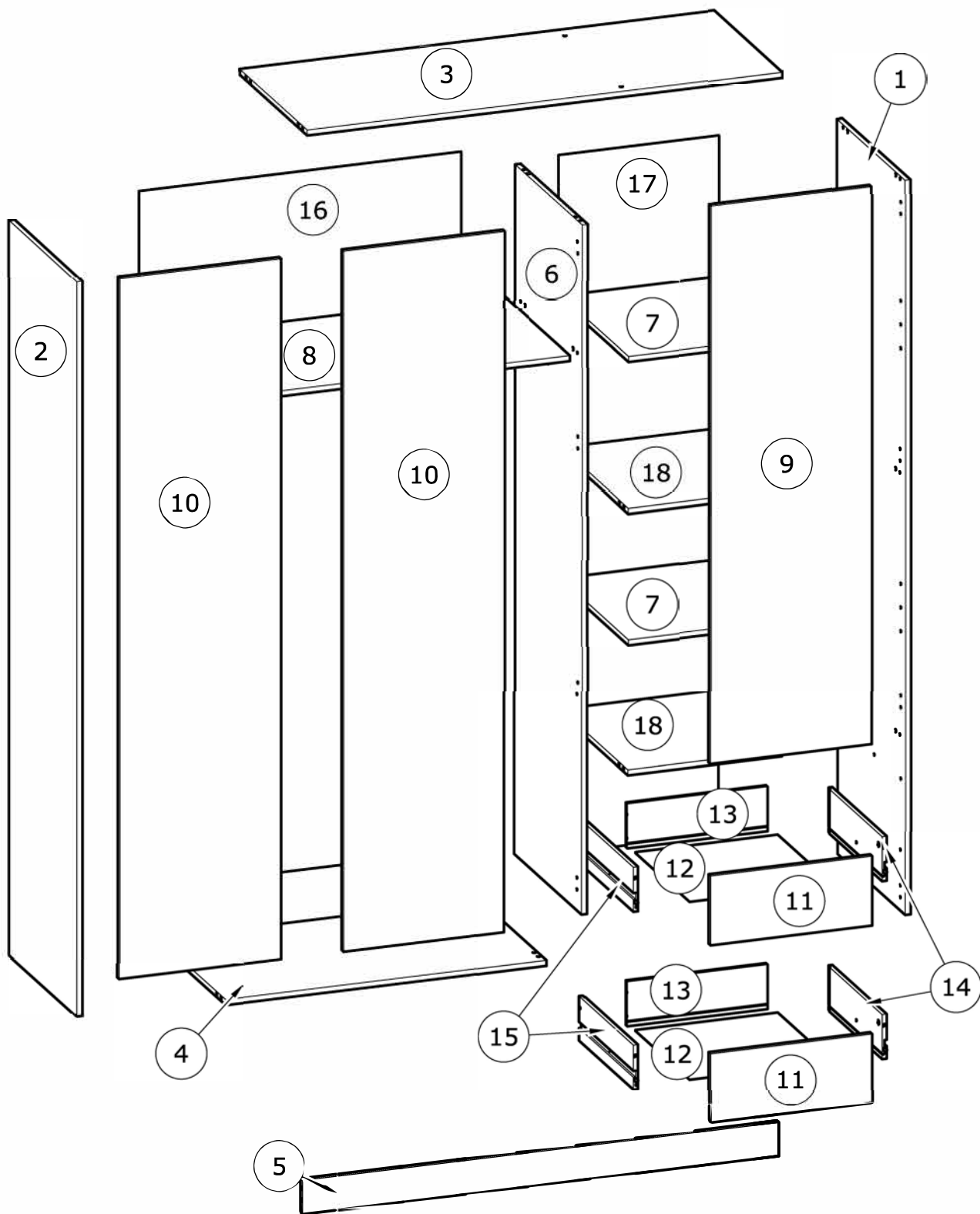

č.	rozměr (mm)	rozměr (palce)	ks
1	1 985 x 500	78 2/16 x 19 11/16	1
2	1 985 x 500	78 2/16 x 19 11/16	1
3	1 292 x 499	50 14/16 x 19 10/16	1
4	875 x 496	34 7/16 x 19 8/16	1
5	1 292 x 91	50 14/16 x 3 9/16	1
6	1 862 x 495	73 5/16 x 19 8/16	1
7	418 x 494	16 7/16 x 19 7/16	2
8	859 x 494	33 13/16 x 19 7/16	1
9	1 508 x 438	59 6/16 x 17 4/16	1

č.	rozměr (mm)	rozměr (palce)	ks
10	1 892 x 438	74 8/16 x 17 4/16	2
11	438 x 187	17 4/16 x 7 6/16	2
12	386 x 398	15 3/16 x 15 11/16	2
13	380 x 120	14 15/16 x 4 12/16	2
14	400 x 120	15 12/16 x 4 12/16	2
15	400 x 120	15 12/16 x 4 12/16	2
16	1 886 x 875	74 4/16 x 34 7/16	1
17	1 886 x 435	74 4/16 x 17 2/16	1
18	418 x 494	16 7/16 x 19 7/16	2

**CZ**

**VAROVÁNÍ: NÁBYTEK MUSÍ BÝT UCHYČEN KE ZDI ABY SE PŘEDEŠLO JEHO PŘEVŘHNUTÍ**

- Při sestavování a instalaci postupujte přesně a pečlivě podle pokynů tohoto návodu k montáži, abyste předešli bezpečnostním rizikům.
- Nábytek uchyťte ke zdi pomocí přichytky, která je součástí dodávky.
- Spojovací materiál pro uchytení ke zdi není součástí dodávky. Použijte spojovací materiál, odpovídající vašemu typu zdi.

**EN**

**WARNING: FURNITURE TO BE ATTACHED TO THE WALL TO PREVENT OVERTURNING**

- Installation shall be carried out exactly according to those instructions-otherwise a safety risk can occur if incorrectly installed;
- Attach the furniture to the wall with the fastening provided for this purpose
- Screw and Pegs are not supplied. Use Screws and pegs adapted to the support.

**DE**

**WARNUNG: DAS MÖBEL MUSS AN DER WAND BEFESTIGT WERDEN, UM ZU VERHINDEN DASS ES KIPPT**

- Um das Produkt korrekt zu installieren und um Risiken für Ihre Sicherheit zu verhindern, die Gebrauchsanleitung genauestens befolgen.
- Das Möbel mit den vorgesehenen Befestigungen an einer Wand befestigen.
- Schrauben und Dübel sind nicht im Lieferumfang enthalten. Passende Schrauben und Dübel verwenden.

**ES**

**ADVERTENCIA: ESTE MUEBLE DEBE ESTAR SIEMPRE FIJO EN LA PARED PARA EVITAR QUE VUELQUE**

- Para instalar correctamente este producto y eliminar los riesgos para la seguridad, seguir exactamente las instrucciones del manual.
- Fijar el mueble a la pared con las sujeciones previstas a este efecto.
- Los tornillos y los tacos no están incluidos. Utilizar tornillos y tacos adaptados al soporte.

**NL**

**WAARSCHUWING: MEUBEL MOET VERPLICHT AAN DE MUUR BEVESTIGD WORDEN ZODAT HET NIET KAN OMVALLEN**

- Om dit product correct te installeren en alle risico's voor uw veiligheid te elimineren, gelieve de instructies in deze handleiding nauwgezet op te volgen.
- Zet het meubel vast aan de muur met de hiertoe voorziene bevestigingen.
- De schroeven en pluggen zijn niet meegeleverd. Gebruik schroeven en pluggen die geschikt zijn voor het materiaal van de muur.

**IT**

**AVVERTENZA: MOBILE DA FISSARE IMPERATIVAMENTE AL MURO PER EVITARE CHE SI RIBALTI**

- Per installare correttamente questo prodotto ed eliminare i rischi per la vostra sicurezza, si prega di seguire esattamente il manuale d'istruzioni.
- Fissare il mobile al muro con gli appositi ganci.
- Le viti e i tasselli non sono forniti. Utilizzare viti e tasselli adatti al supporto.

**PT**

**ADVERTÊNCIA: MÓVEL A FIXAR OBRIGATORIAMENTE À PAREDE PARA EVITAR A SUA QUEDA**

- Para instalar corretamente este produto e eliminar os riscos para a sua segurança, é favor seguir exatamente este manual de instruções.
- Fixe o móvel à parede com as fixações previstas para o efeito
- Os parafusos e as cavilhas não são fornecidos. Utilize parafusos e cavilhas adaptados ao suporte.

**PL**

**OSTRZEŻENIE: MEBEL NALEŻY PRZYMOCOWAĆ DO ŚCIANY, ABY UNIKNAĆ JEGO PRZEWROCENIA**

- Aby prawidłowo zainstalować ten produkt i wyeliminować zagrożenie dla bezpieczeństwa użytkownika, należy postępować zgodnie z niniejszą instrukcją.
- Przymocować mebel do ściany za pomocą mocowań przewidzianych w tym celu.
- Śruby i nakrętki nie znajdują się w zestawie. Użyć śrub i nakrętek dostosowanych do wspornika.

**CR**

**UPOZORENJE : UČVRSTITE ORMARIĆ NA ZID KAKO BISTE SPRIJEČILI NJEGOVO LJULJANJE**

- Kako biste pravilno postavili ovaj proizvod i uklonili sigurnosne rizike kojima se izlažete, pridržavajte se strogo ovog priručnika s uputama.
- Postavite ormarić na zid pripadajućim sponama.Vijci i svornjci ne isporučuju se. Upotrijebite nosne vijke i svornjke.

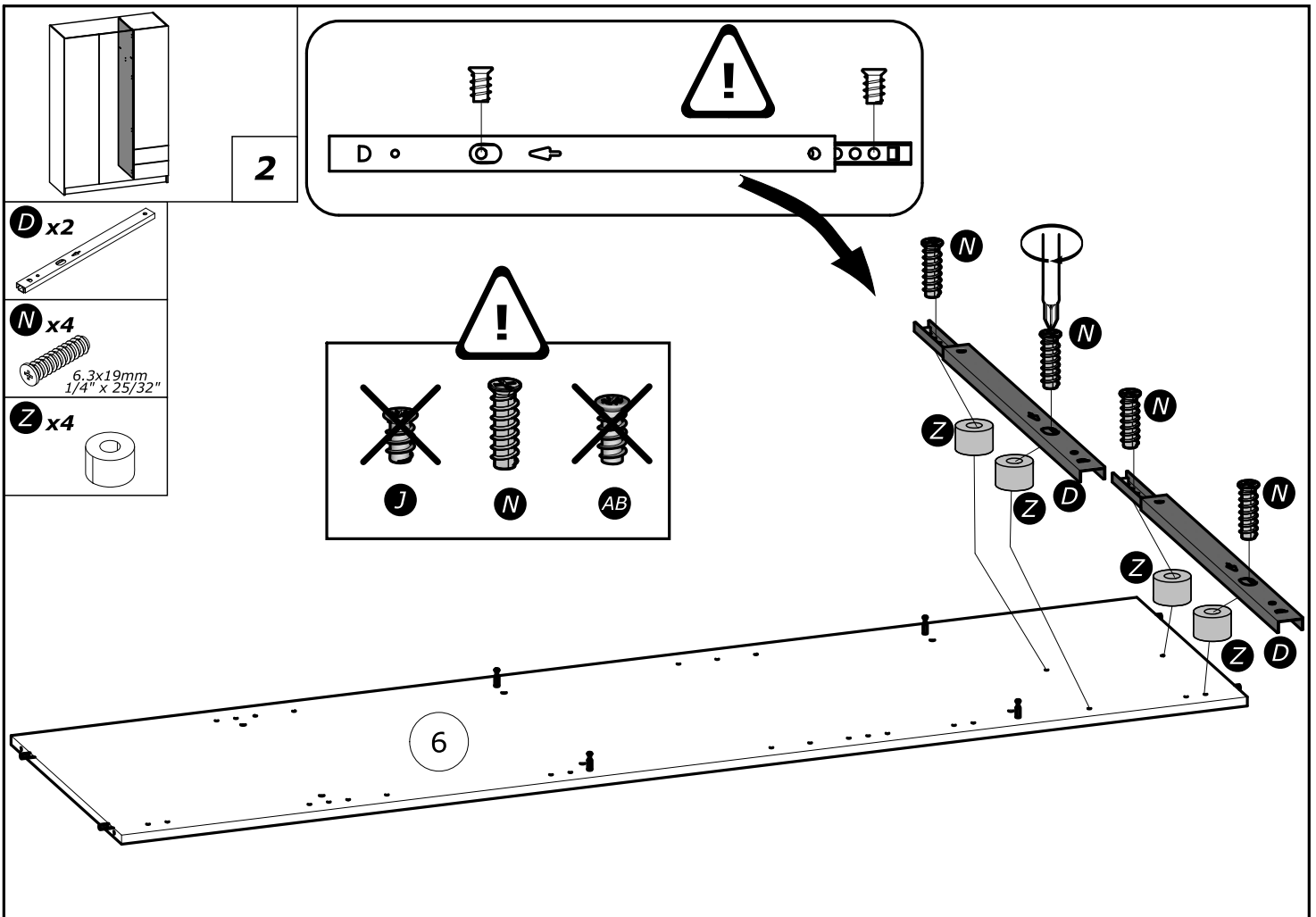
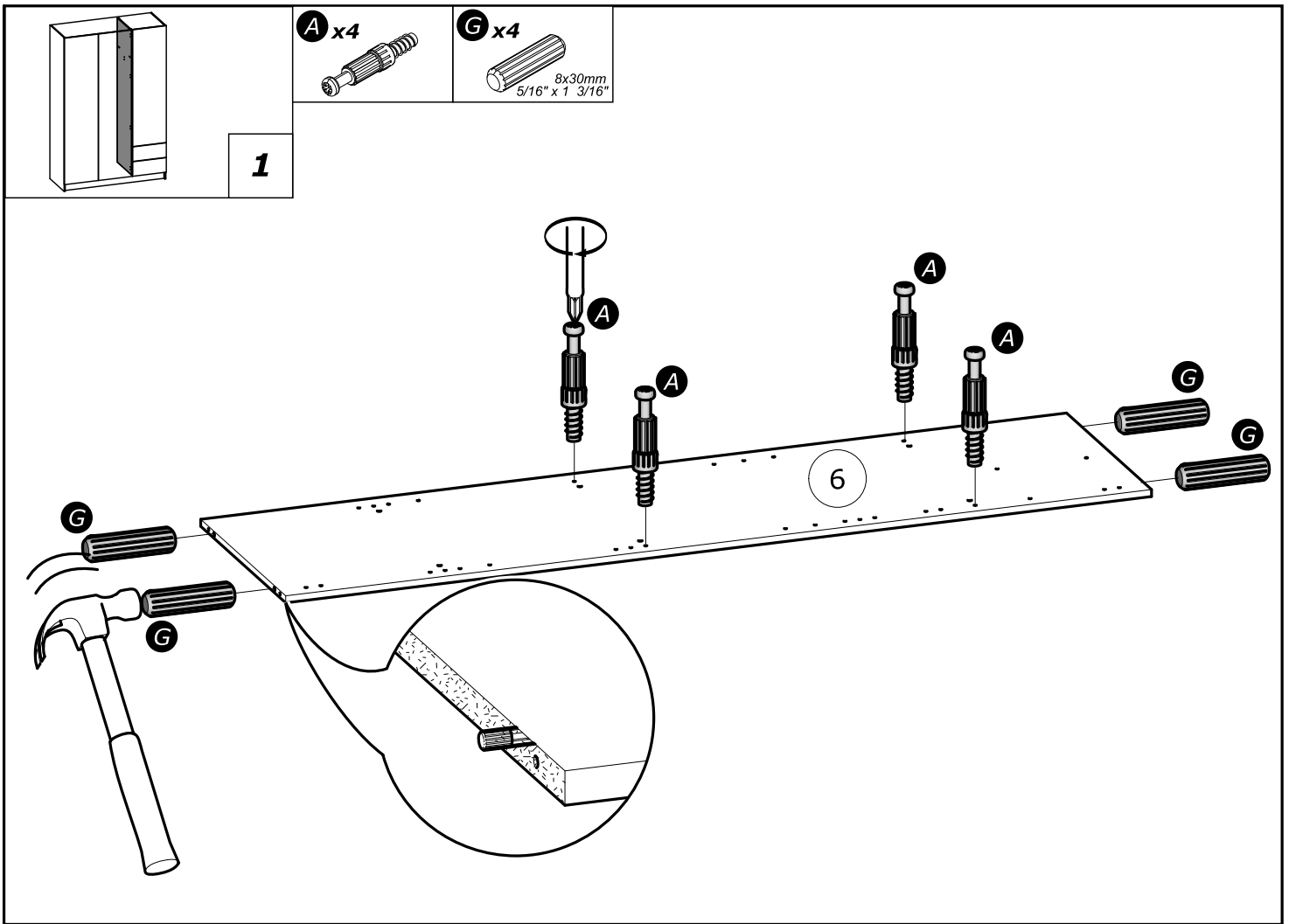

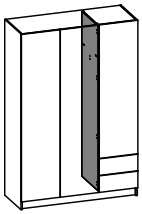

3

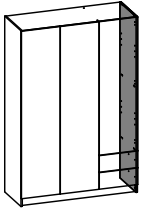
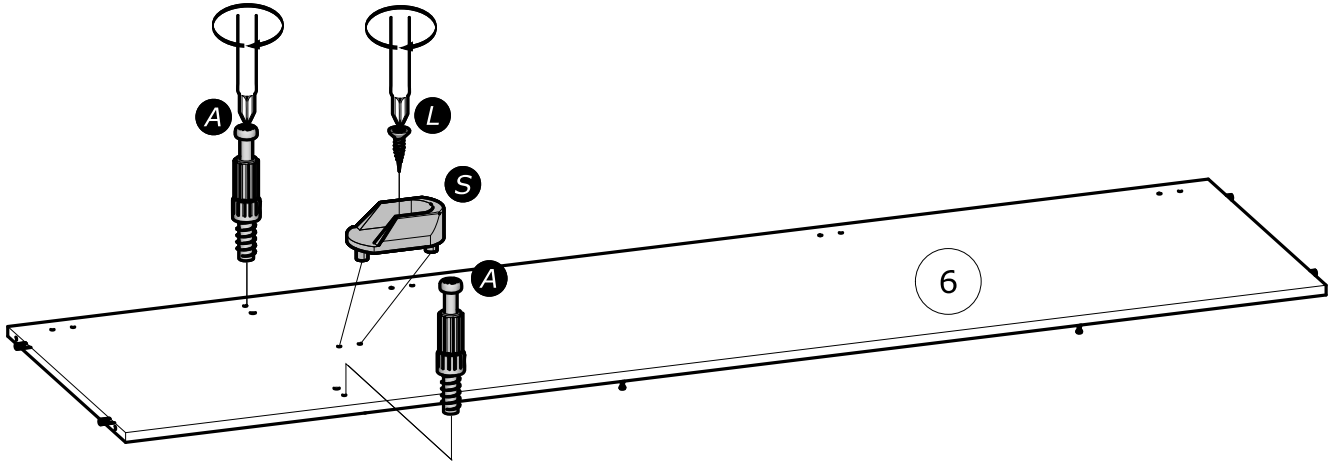
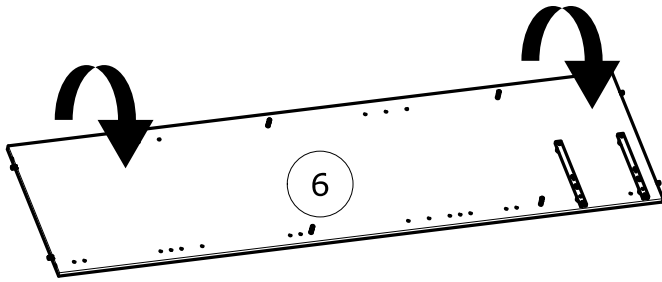
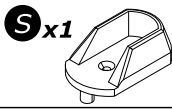
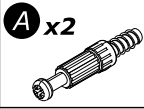

4

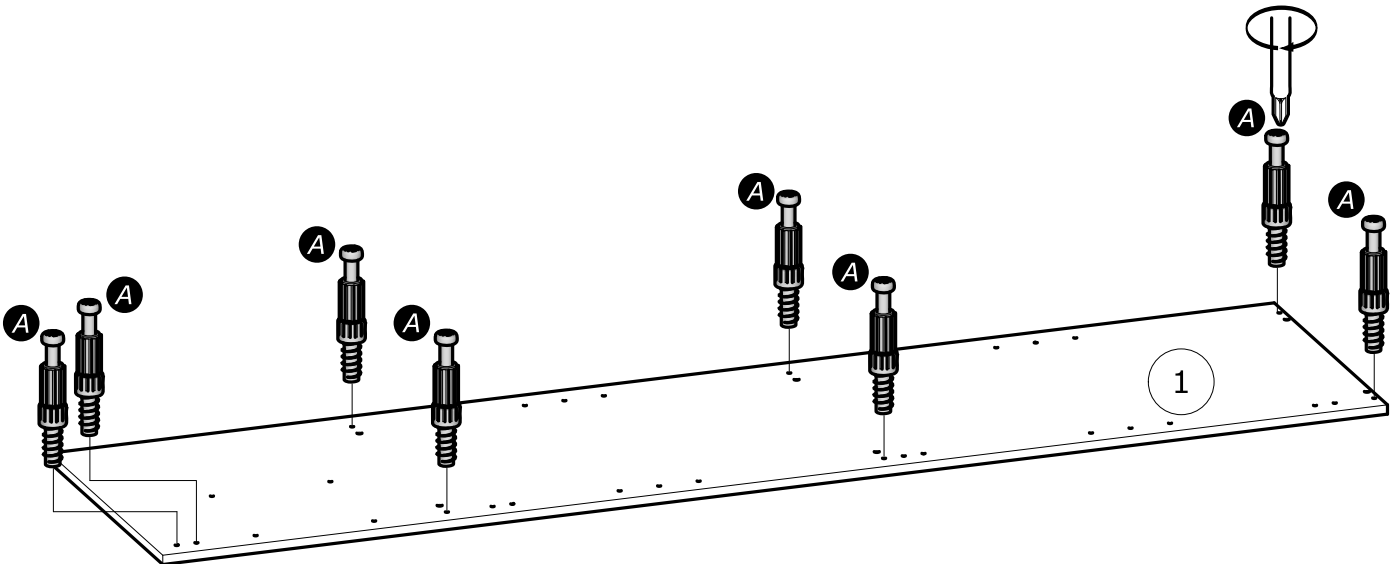
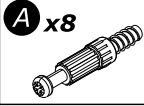



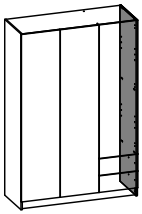

5

**D** x2

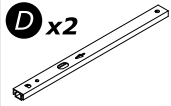

**J** x4

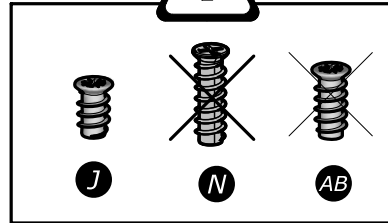
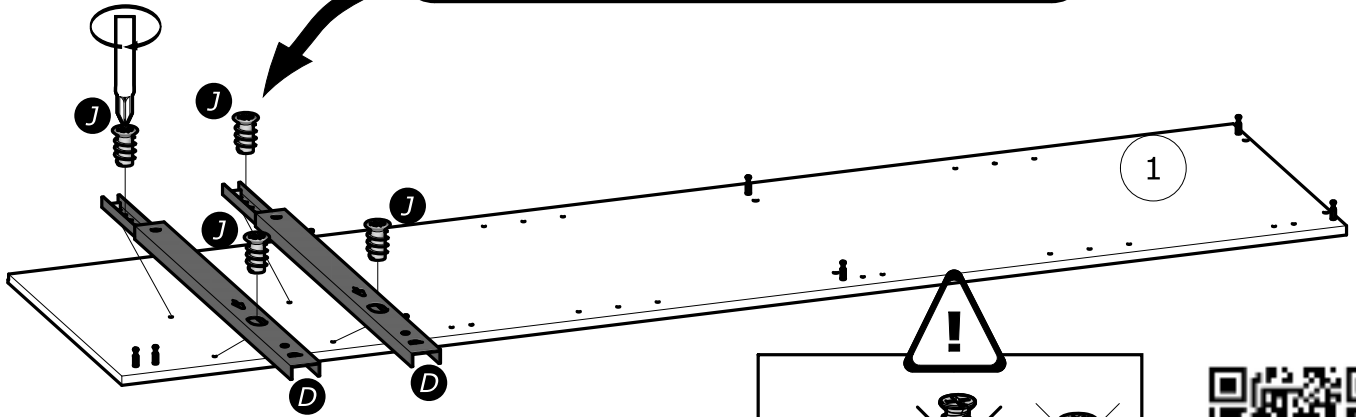
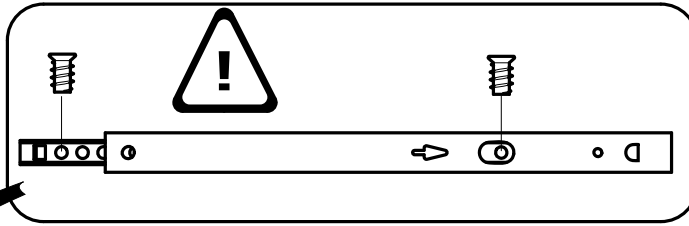
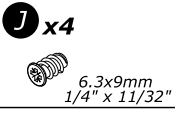

[www.Demeyere.fr](http://www.Demeyere.fr)

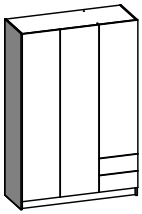

6

**A** x8

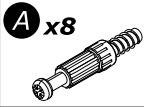

**L** x1

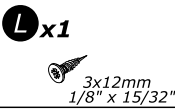

**S** x1

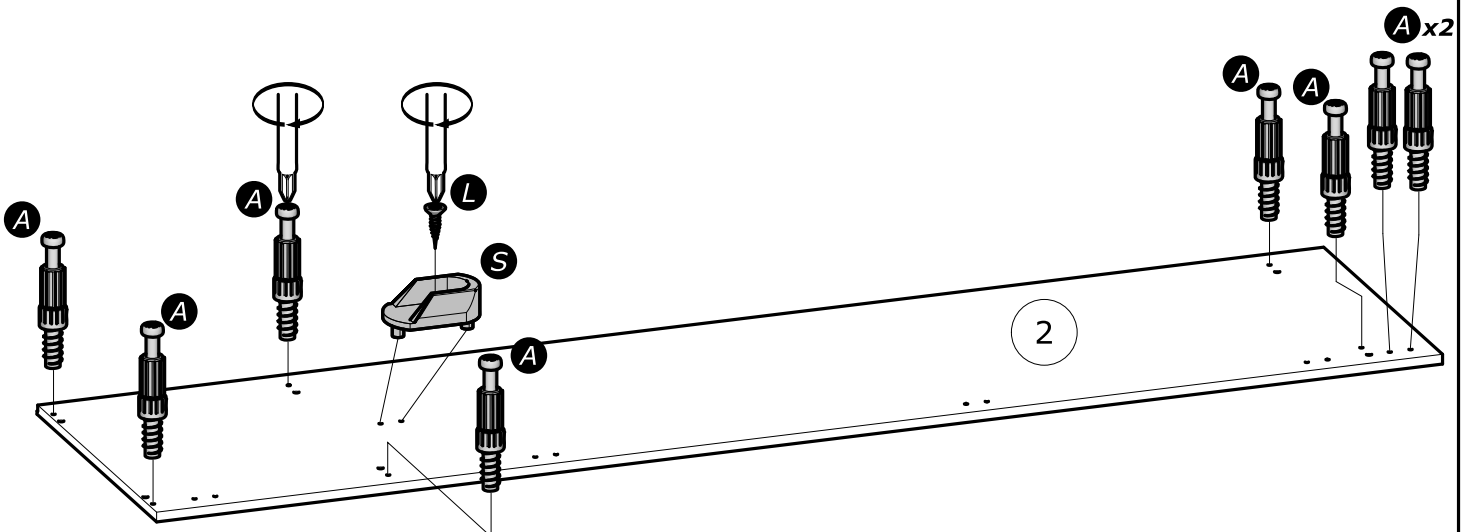
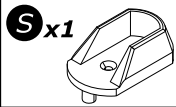

**G** x4  
8x30mm  
5/16" x 1 3/16"

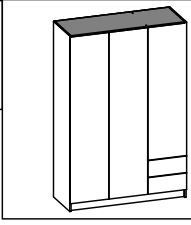

**7**

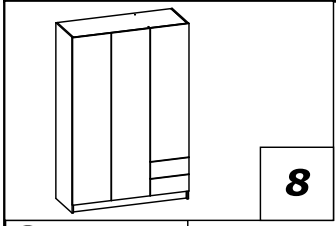
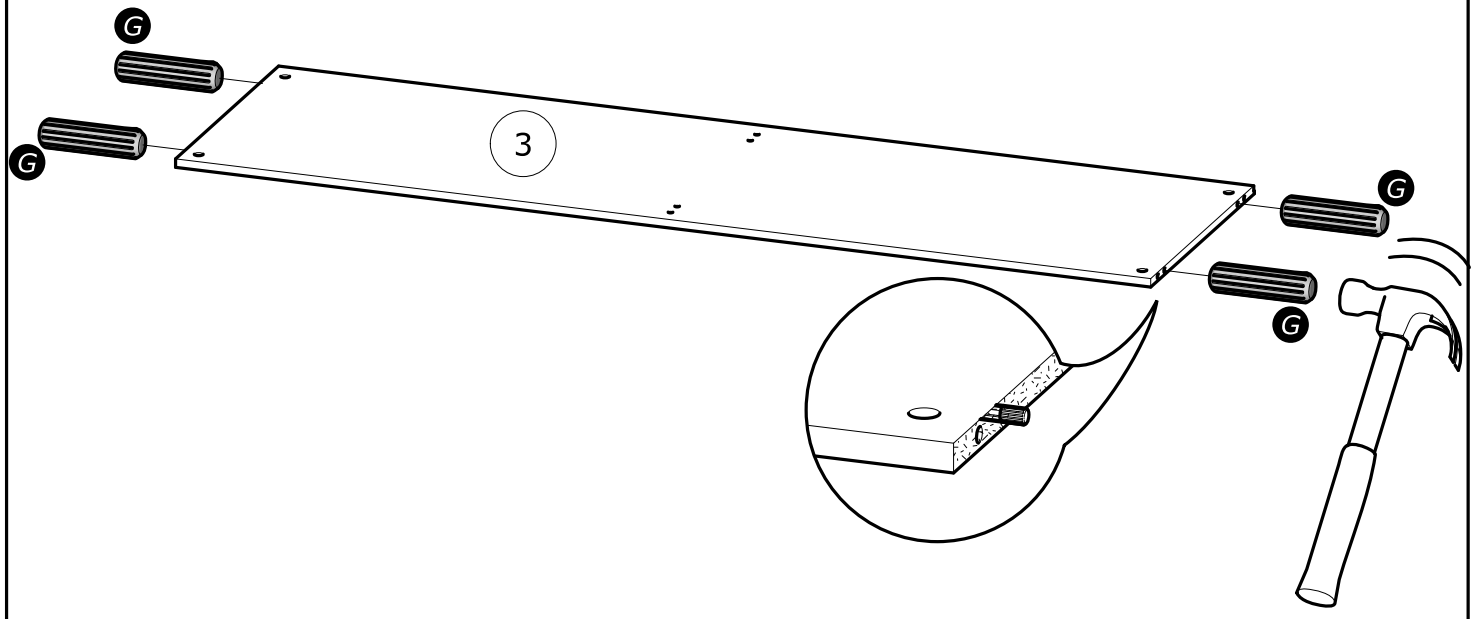

**8**

**C**  
**AD** x2  
7x50mm  
9/32" x 1 31/32"

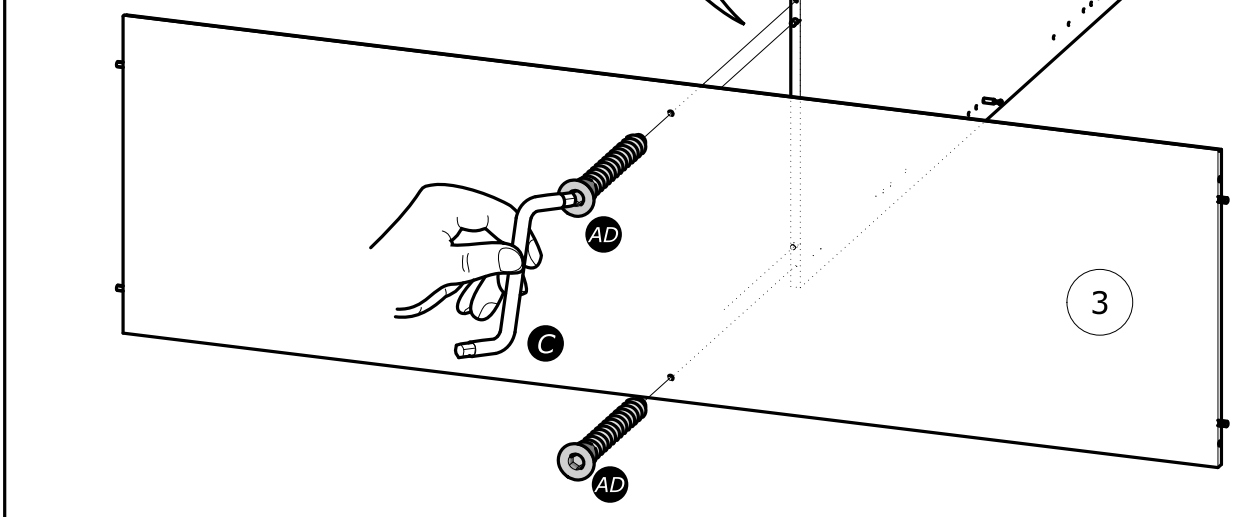
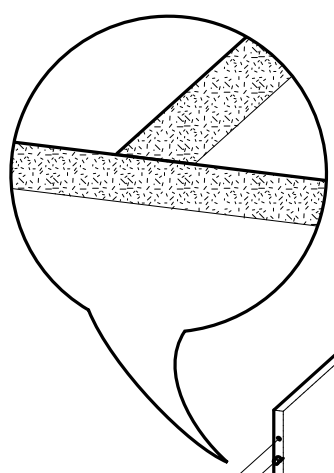

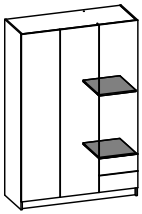

9

**G** x8  
8x30mm  
5/16" x 1 3/16"

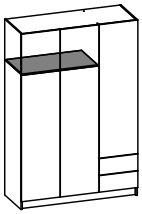
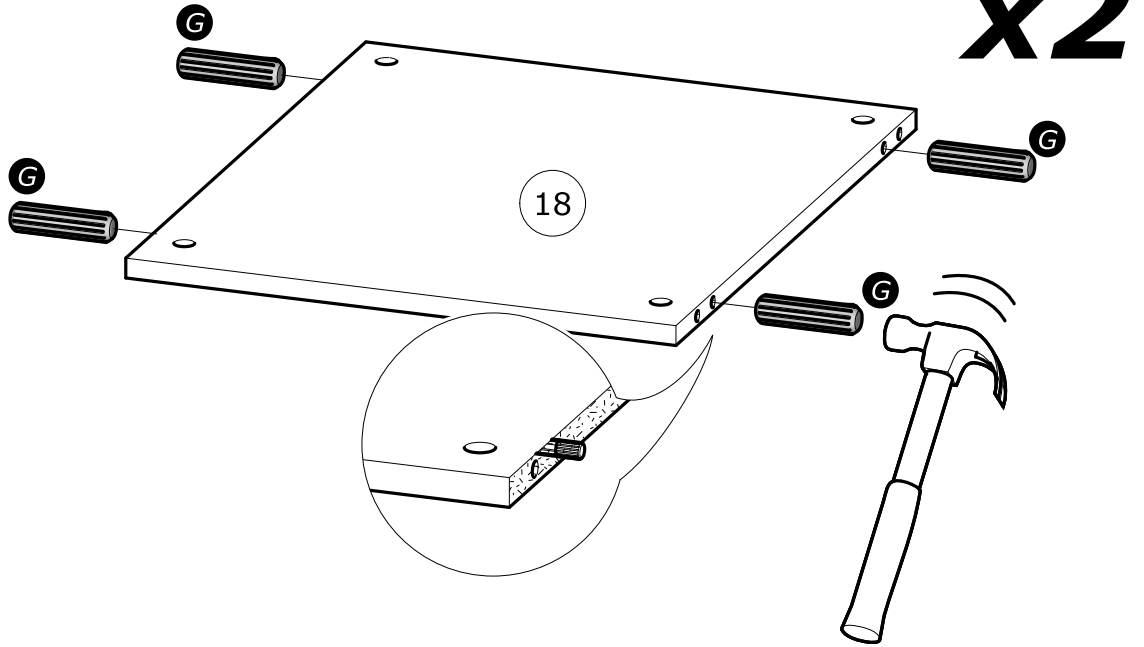

10

**G** x4  
8x30mm  
5/16" x 1 3/16"

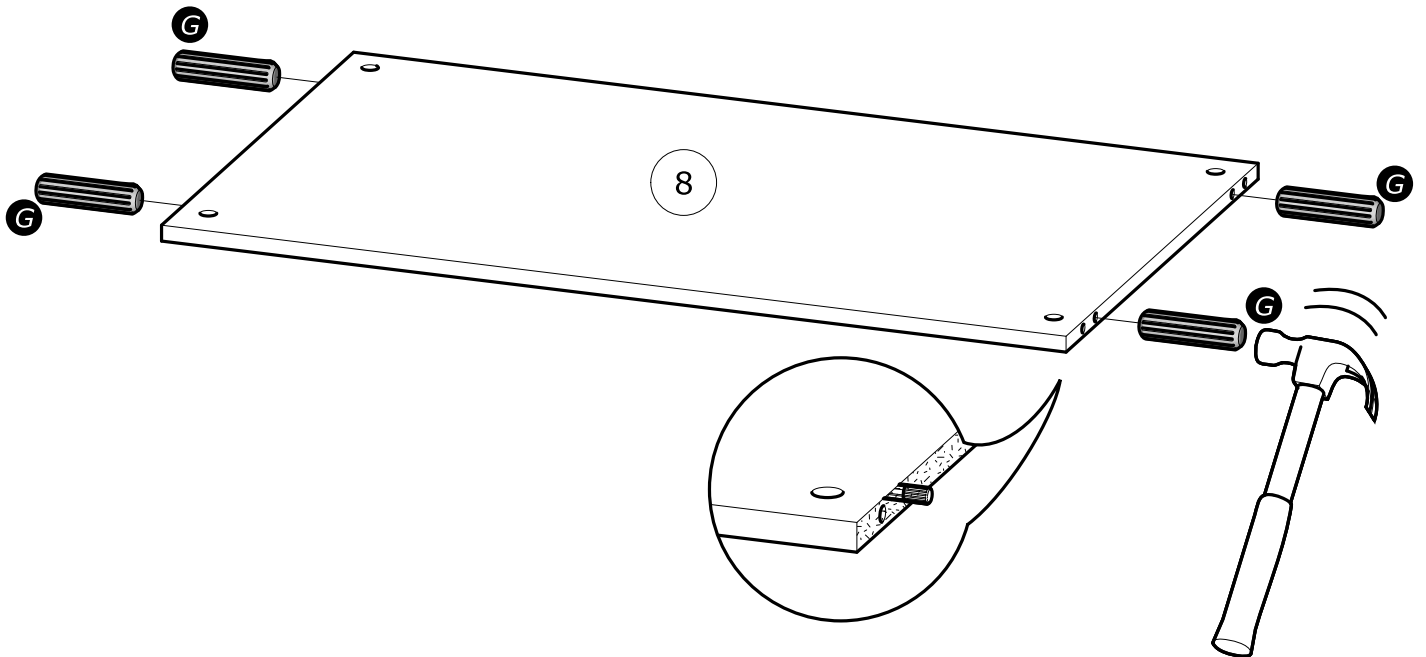

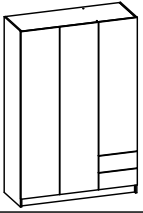

11

**B** x4



Ø15mm  
Ø19/32"

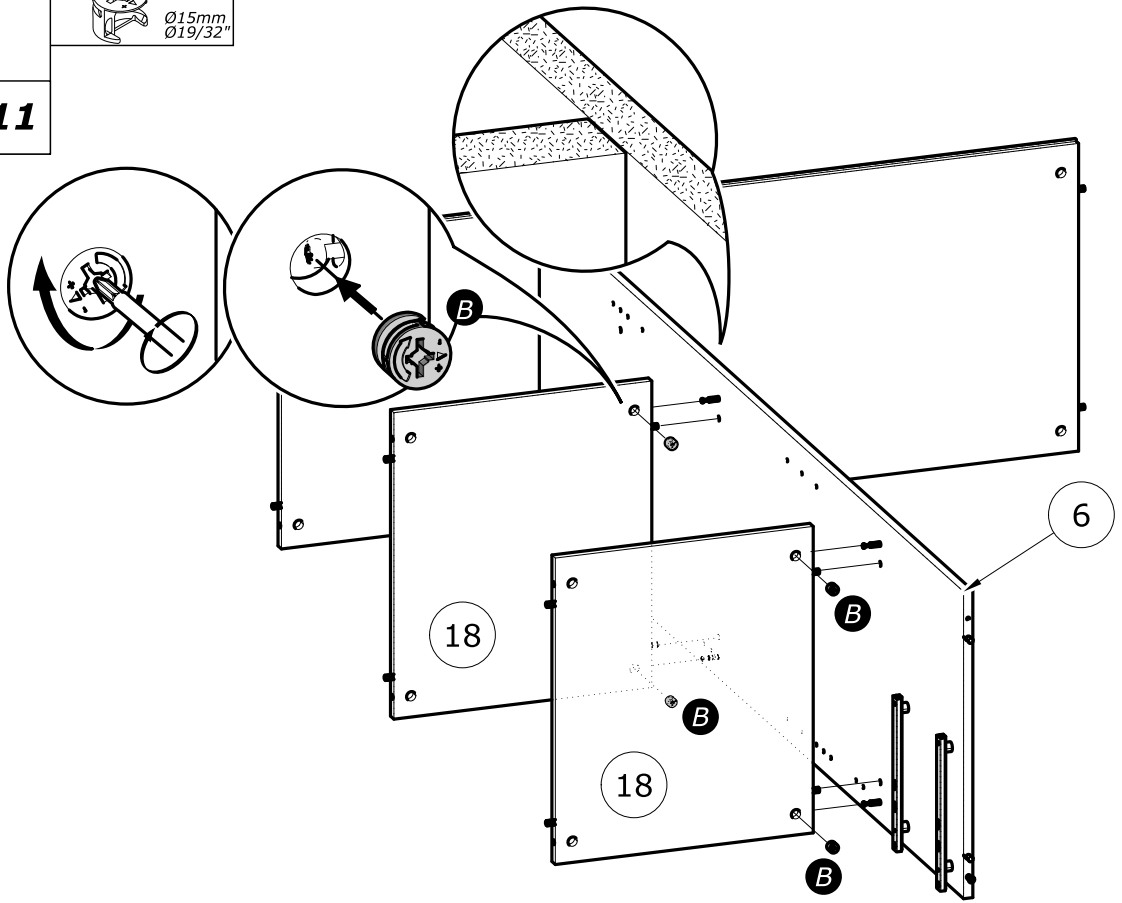

**B** x6



Ø15mm  
Ø19/32"

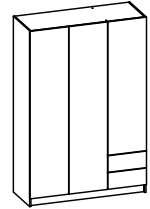

12

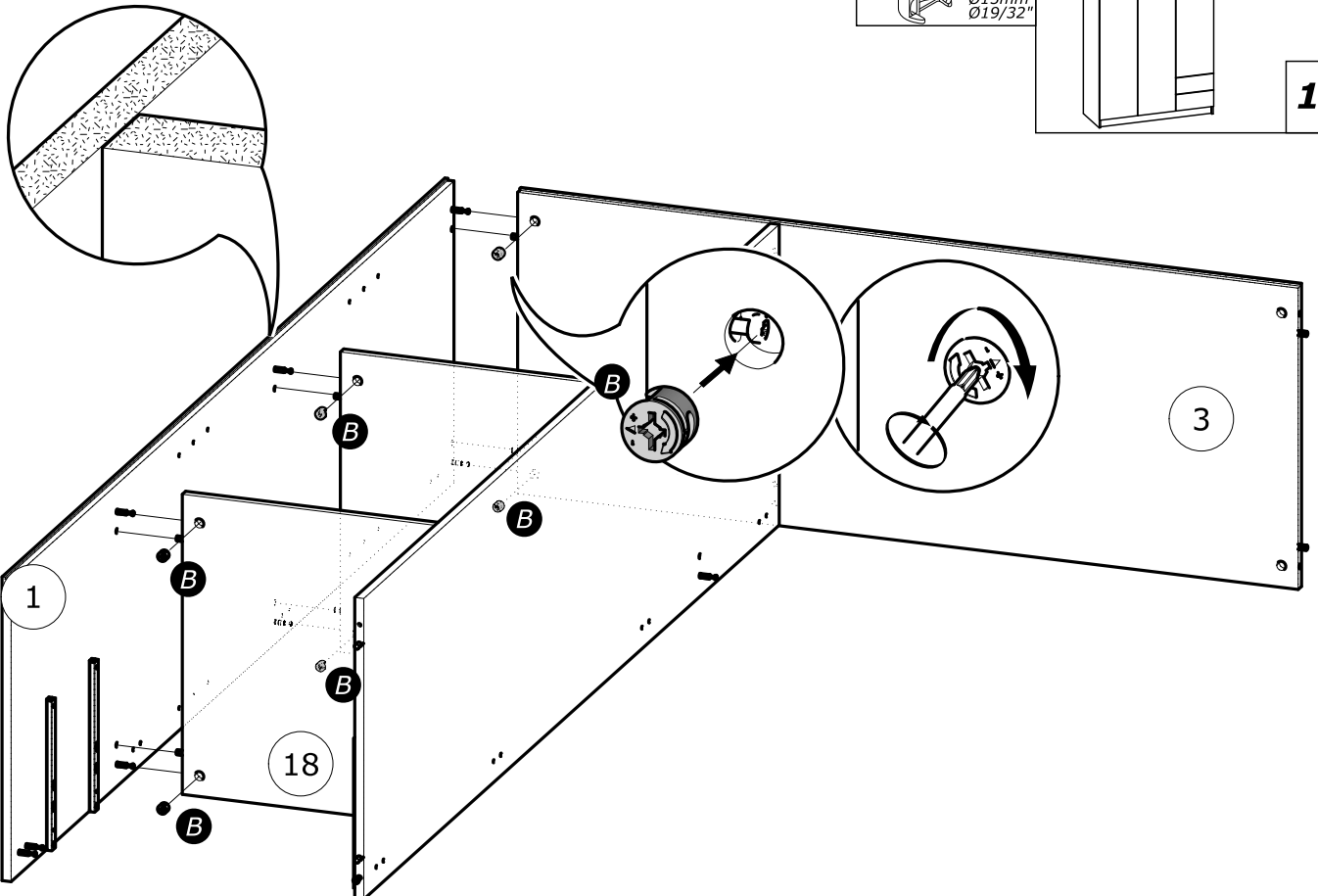

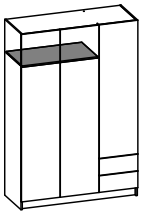

13

**B** x2  
Ø15mm  
Ø19/32"

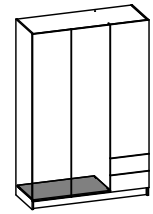
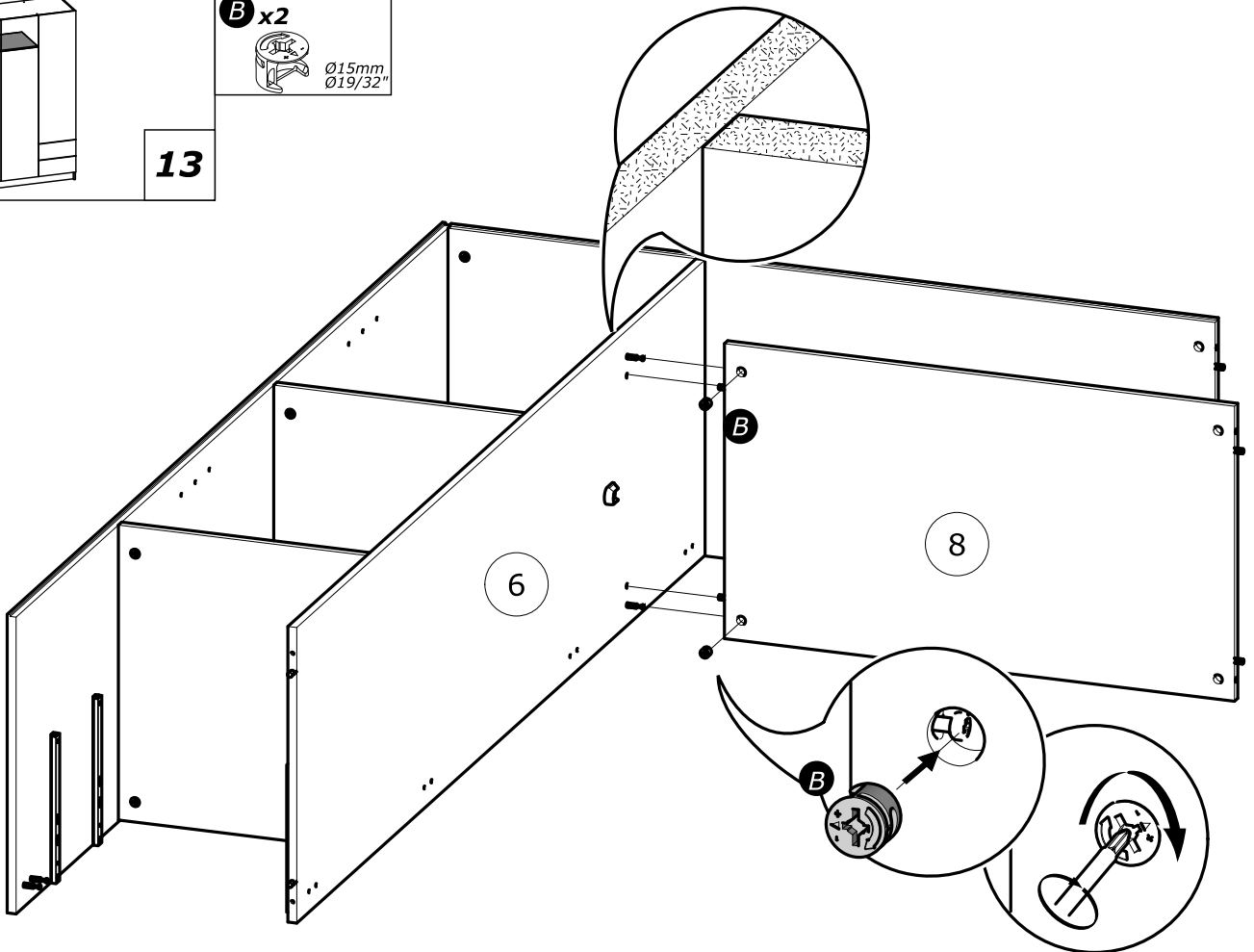

14

**G** x2  
8x30mm  
5/16" x 1 3/16"

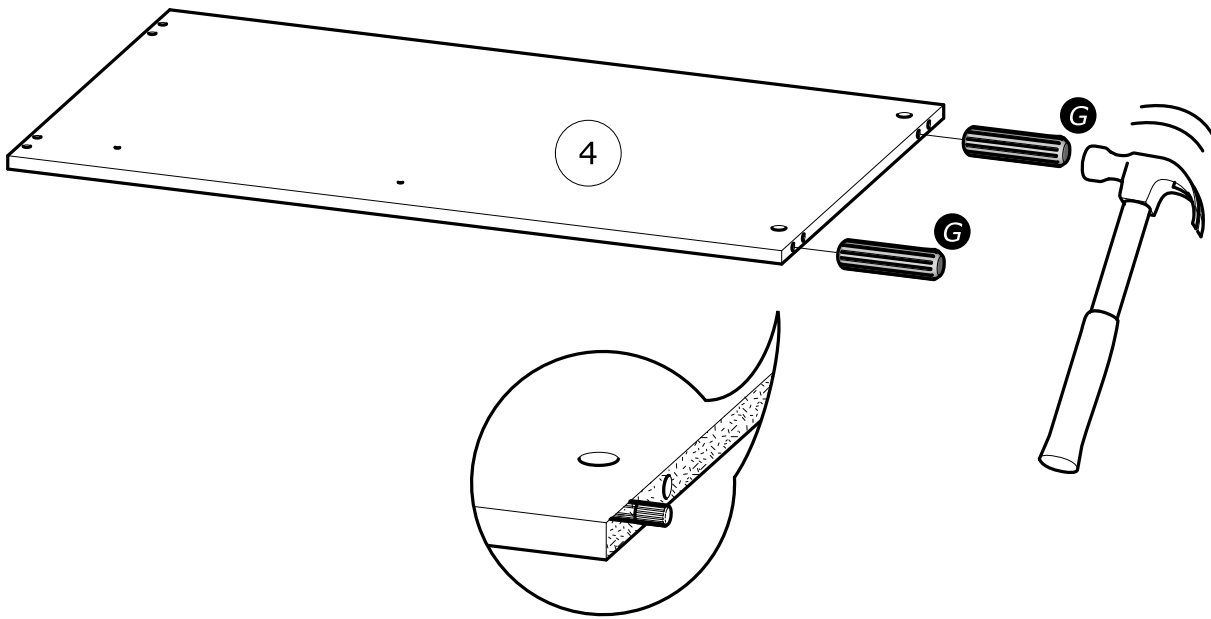

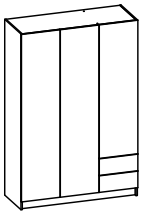

15

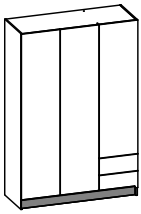
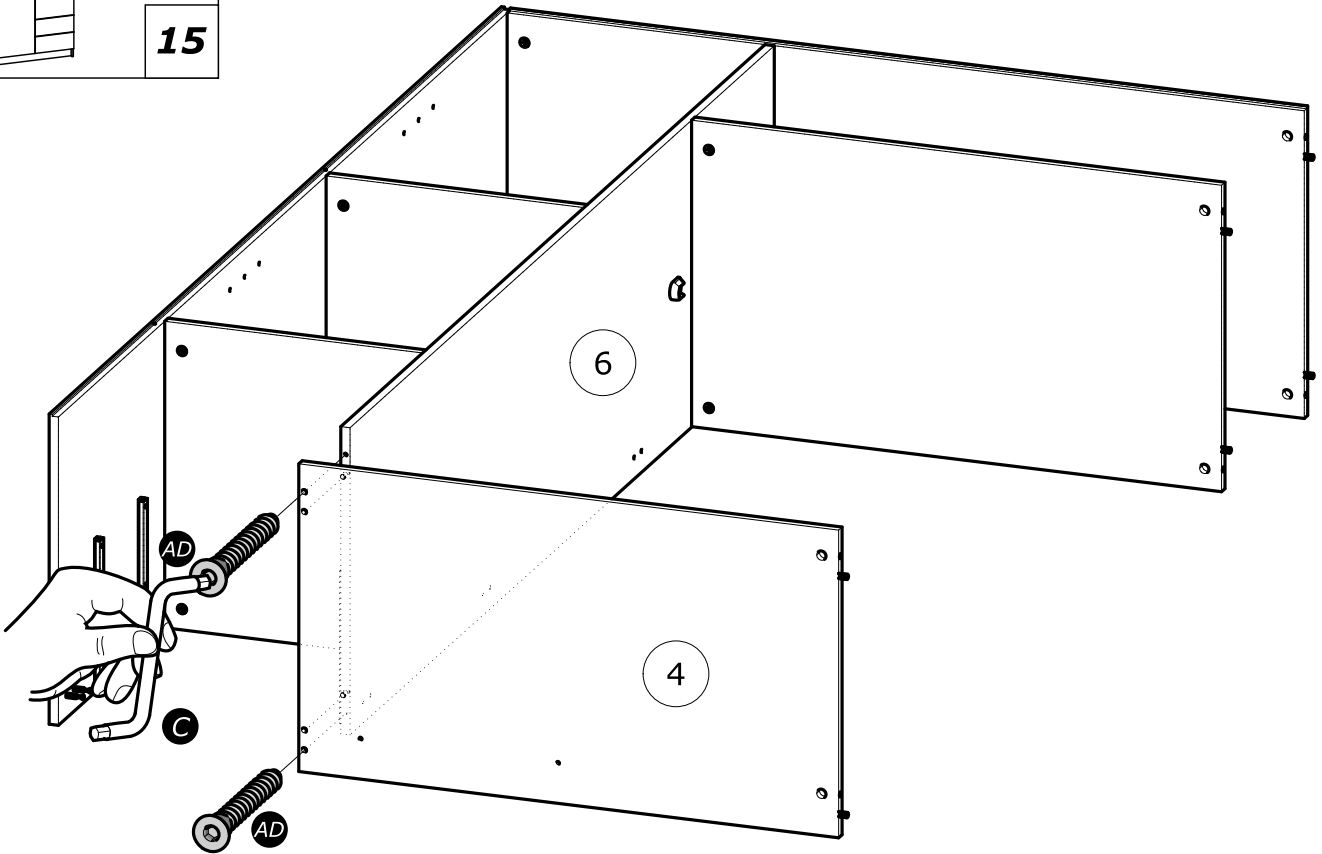
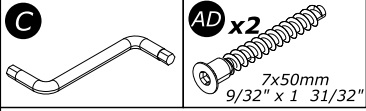

16

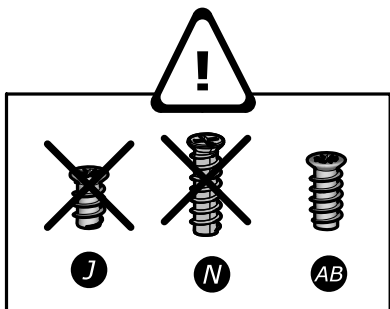
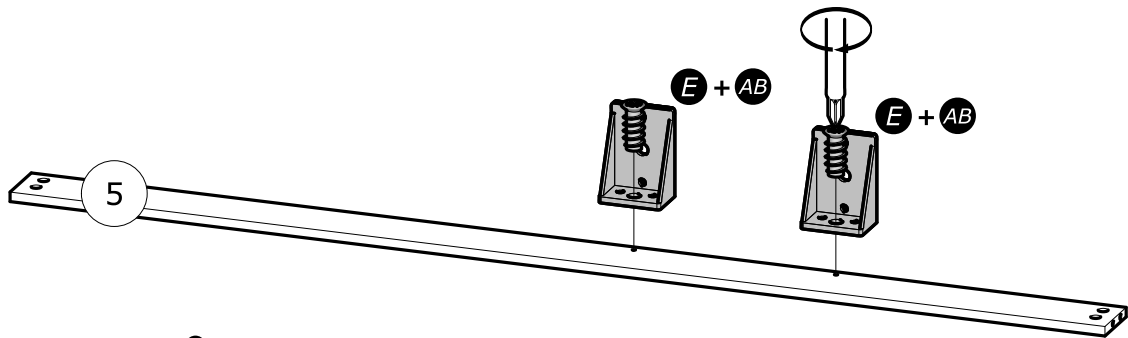
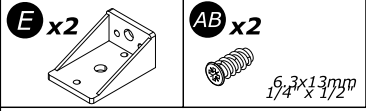

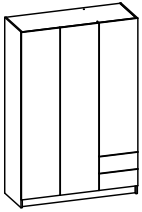

17

**B** x2



Ø15mm  
Ø19/32"

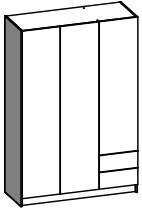
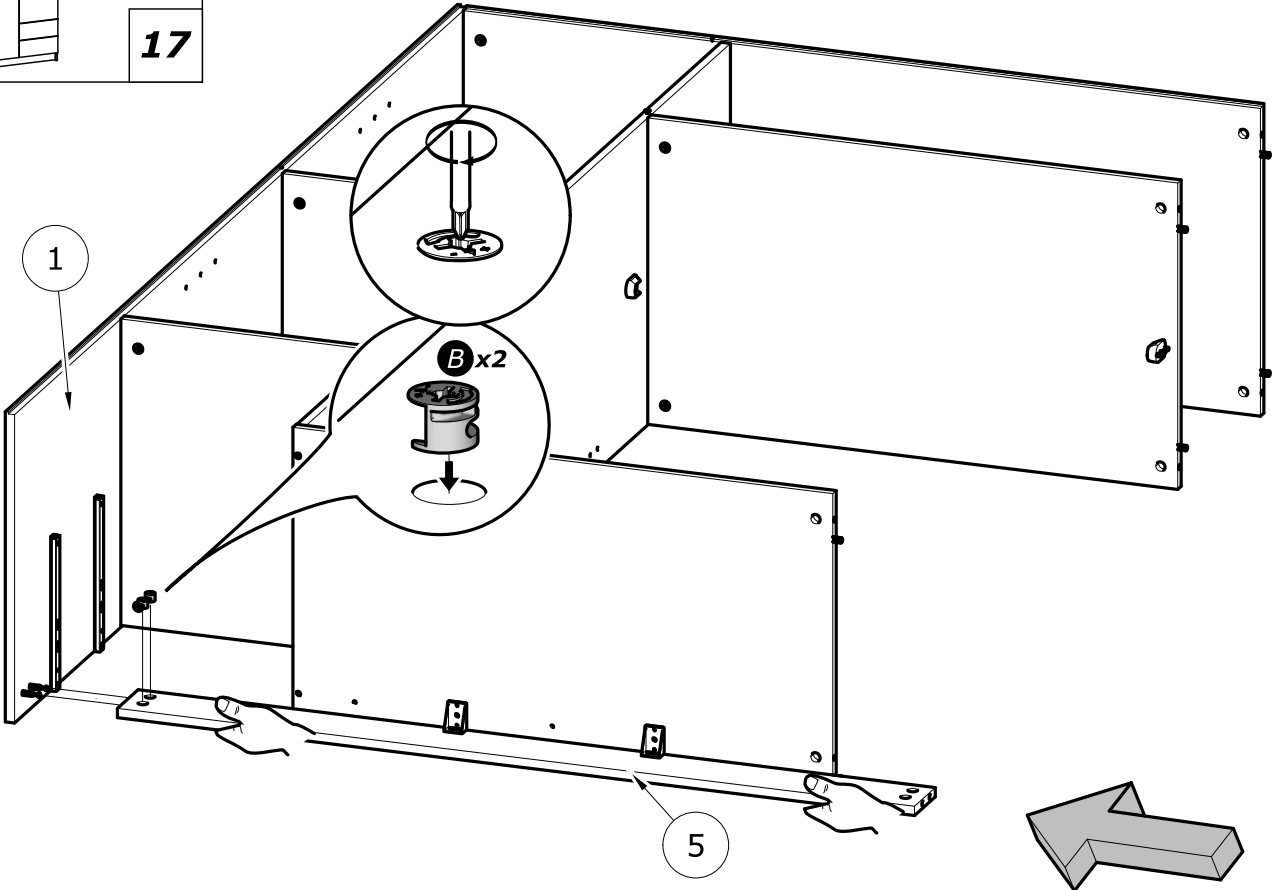

18

**B** x8



Ø15mm  
Ø19/32"

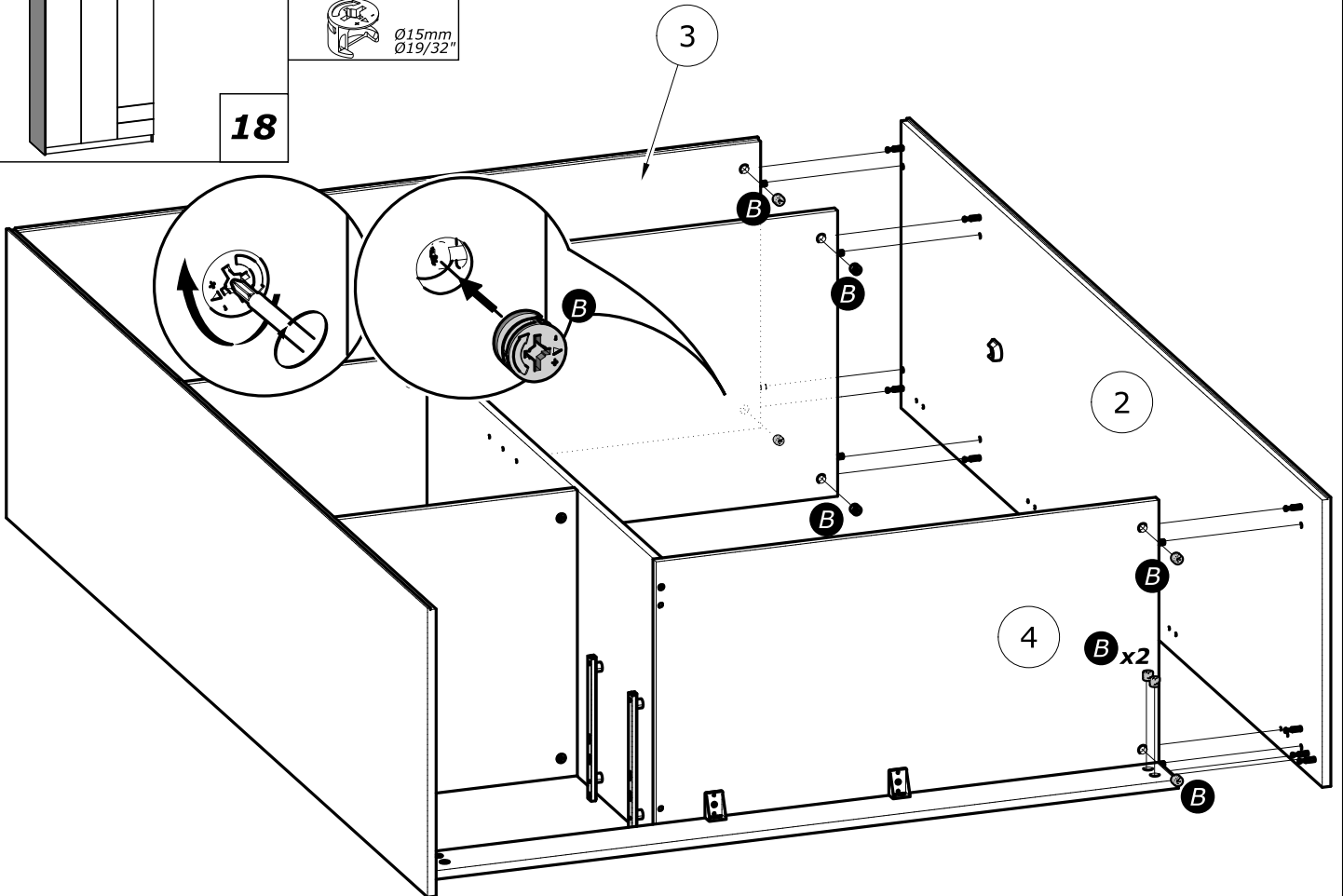

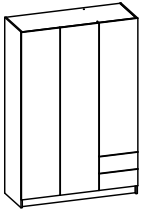

19

AB x2



6.3x13mm,  
1/4" x 1/2"



J



N



AB

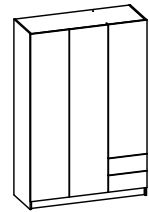
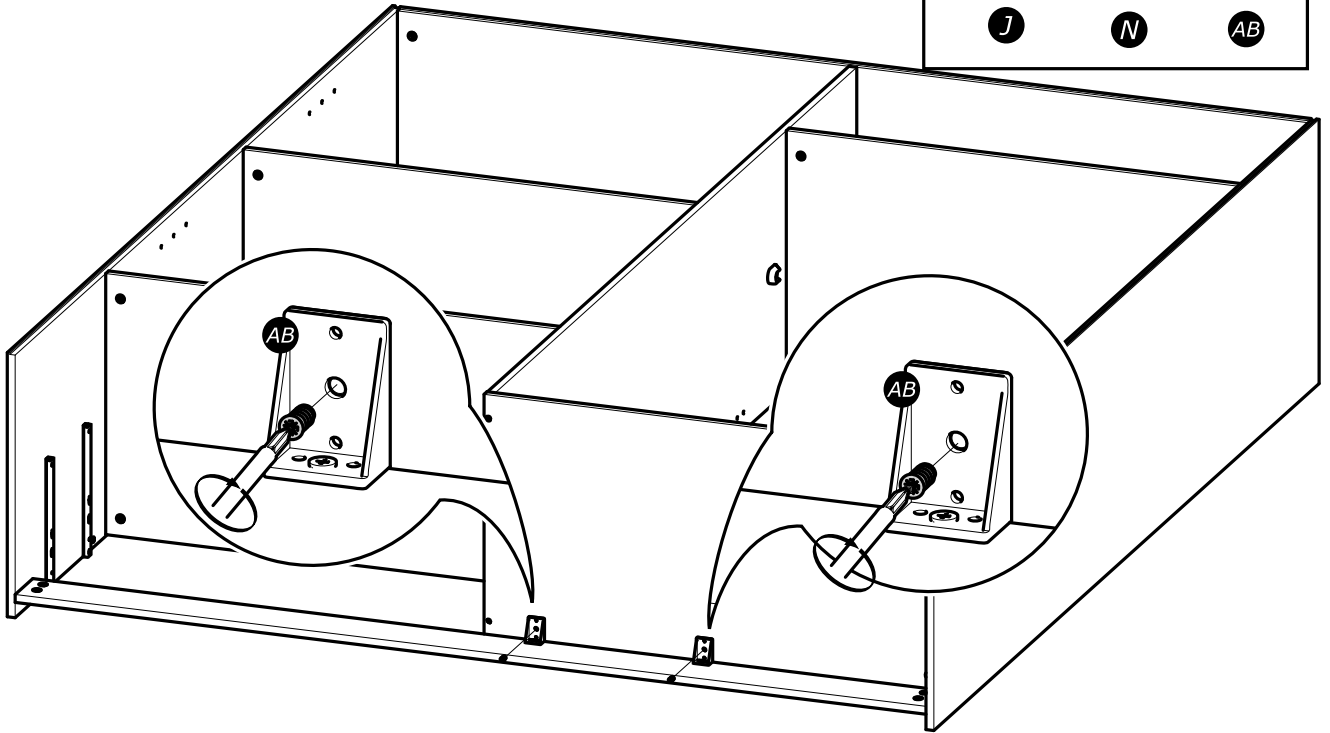

20

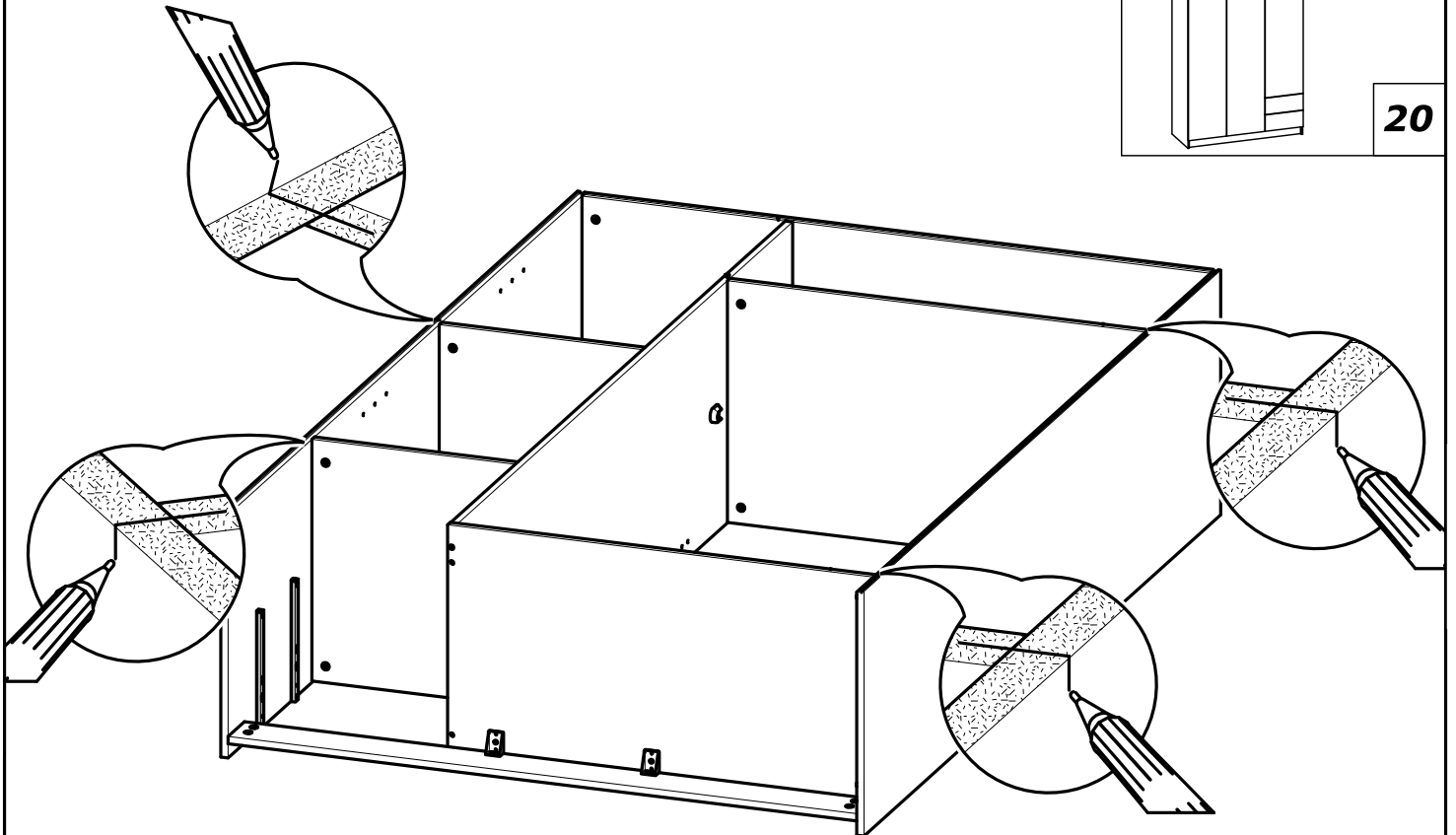



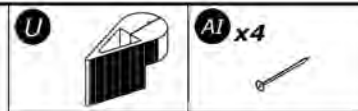

21



[www.Demeyere.fr](http://www.Demeyere.fr)

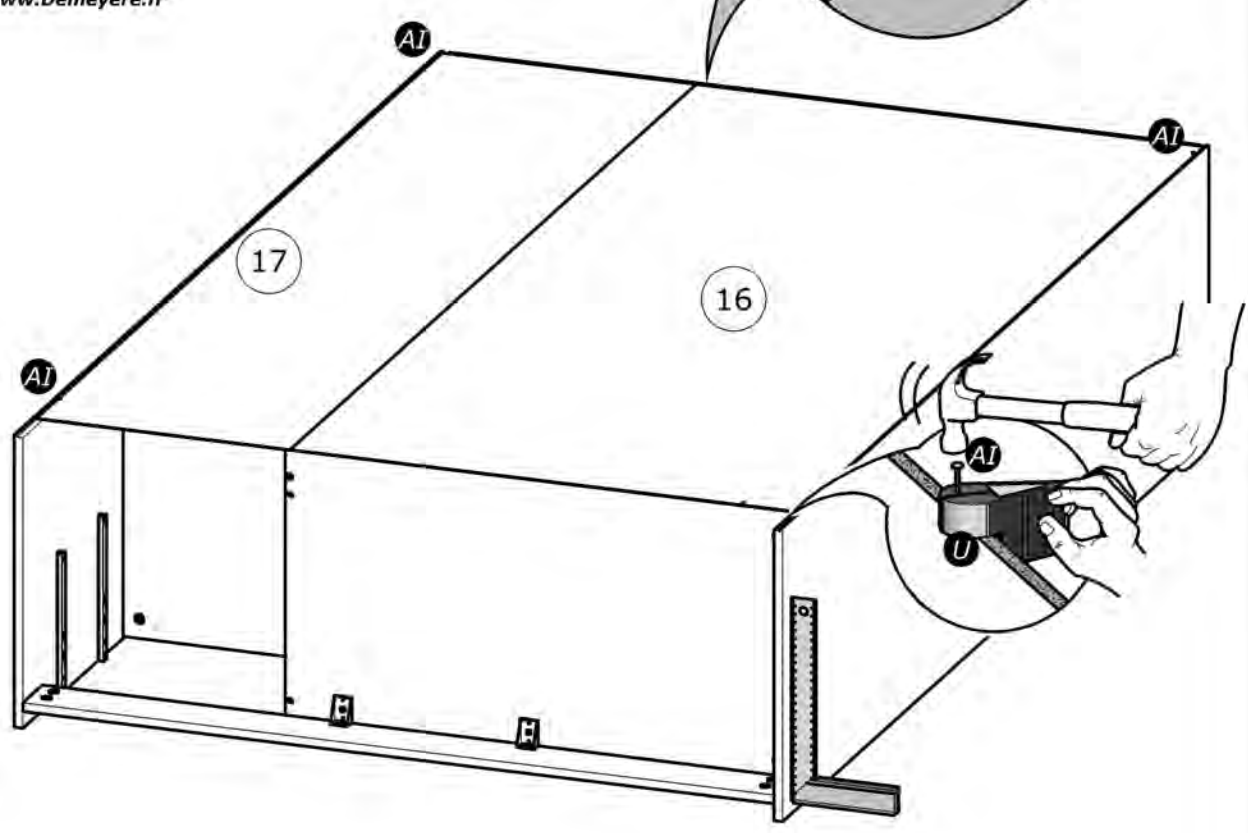
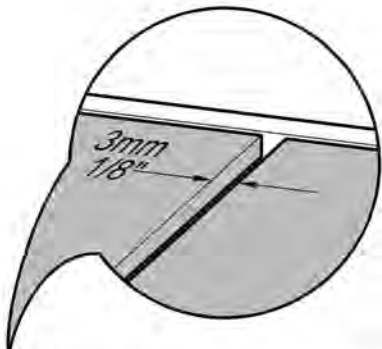

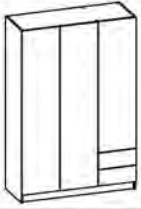

22

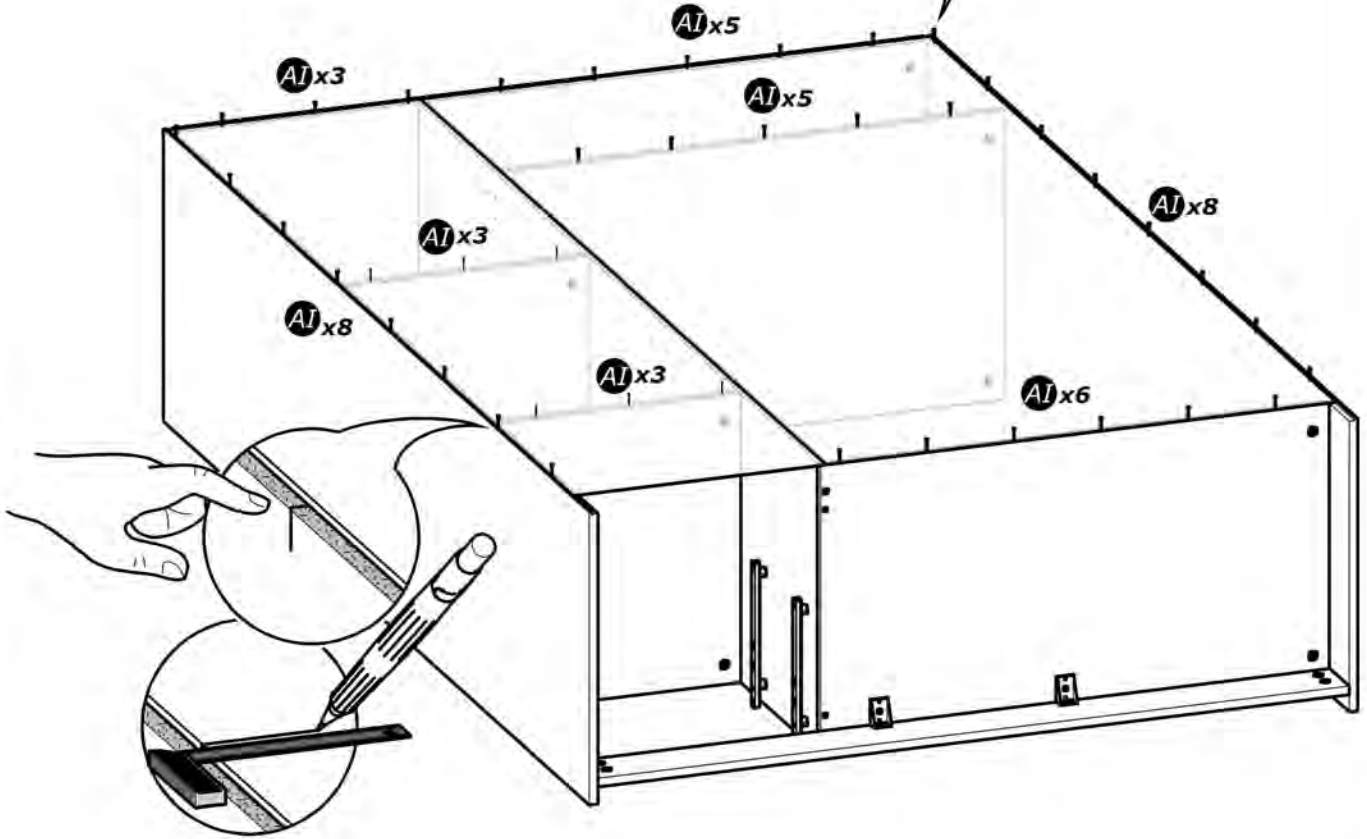
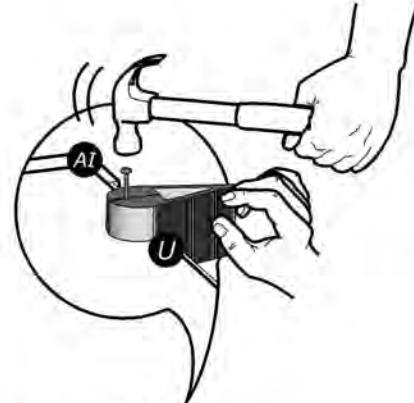
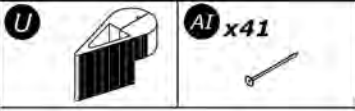

[www.Demeyere.fr](http://www.Demeyere.fr)

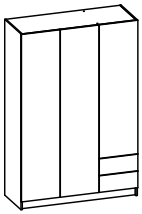

23

**K** x6

3x16mm  
1/8" x 5/8"

**AG** x6

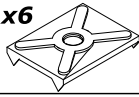

**x6**

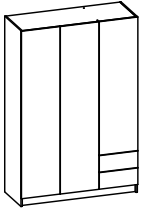
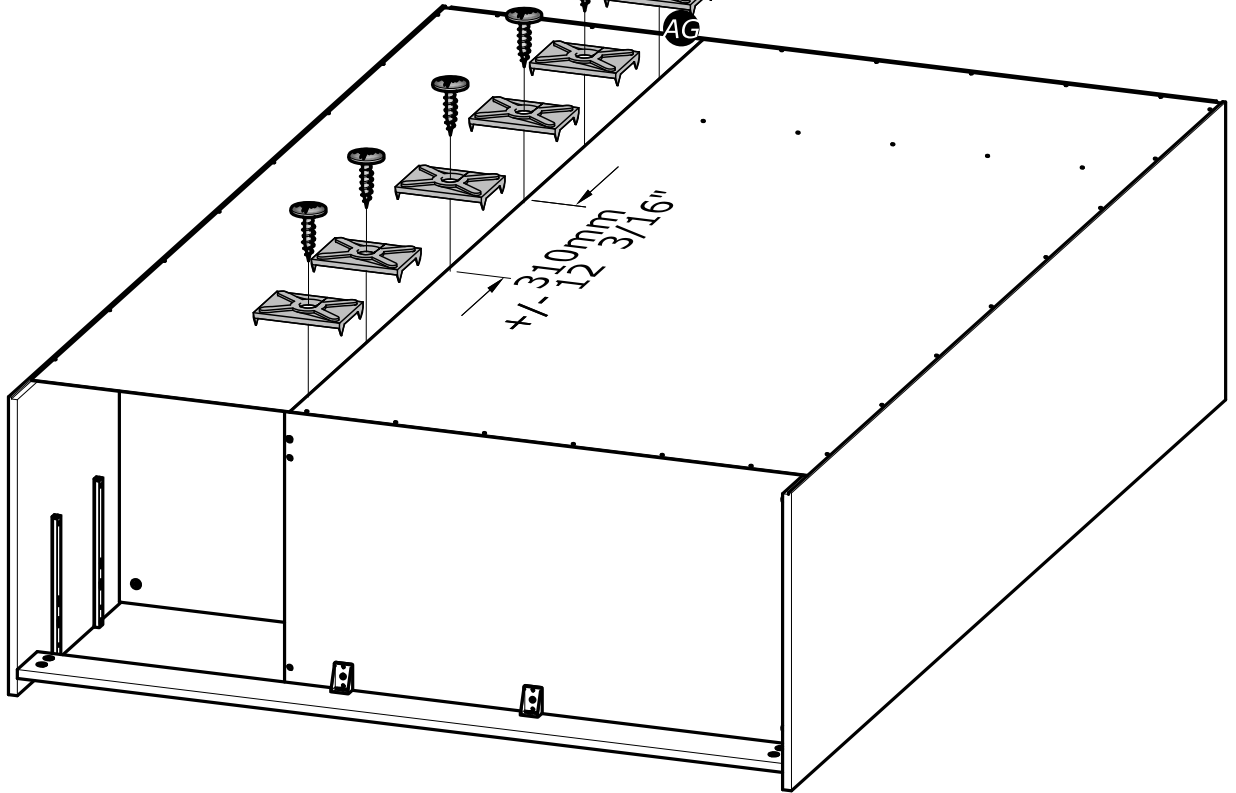

24

**K** x6

3x16mm  
1/8" x 5/8"



**K** x6

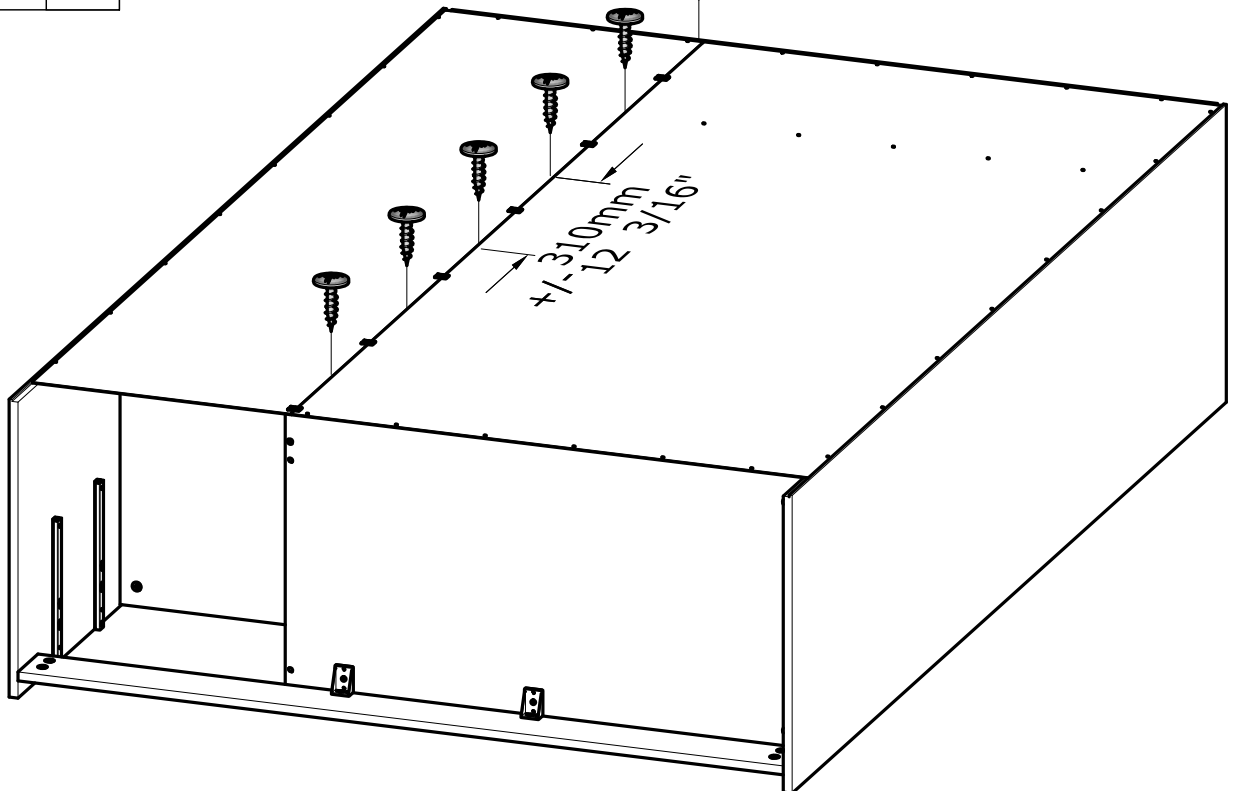

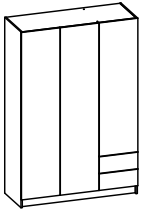

25

M x4



3.5x15mm  
1/8" x 19/32"

AE x1

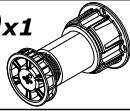

1°

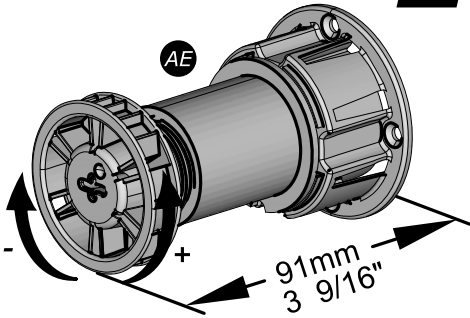

2°

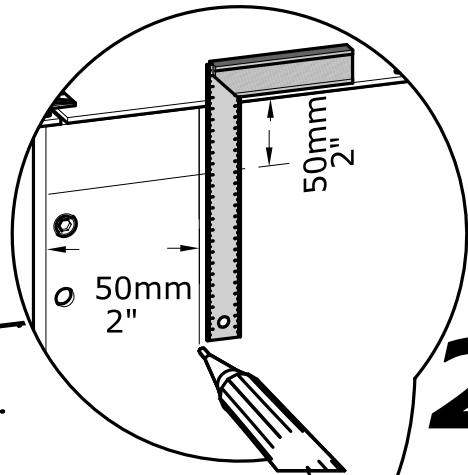

3°

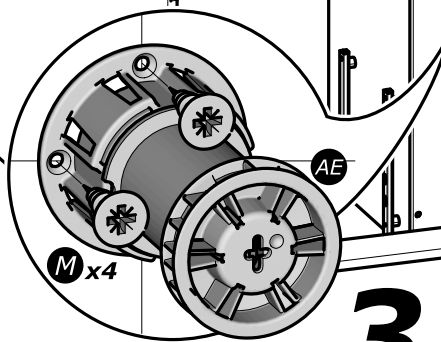
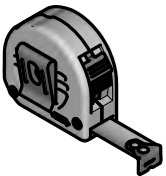

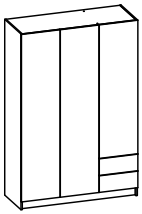

26

M x2

3.5x15mm  
1/8" x 19/32"

AJ x2

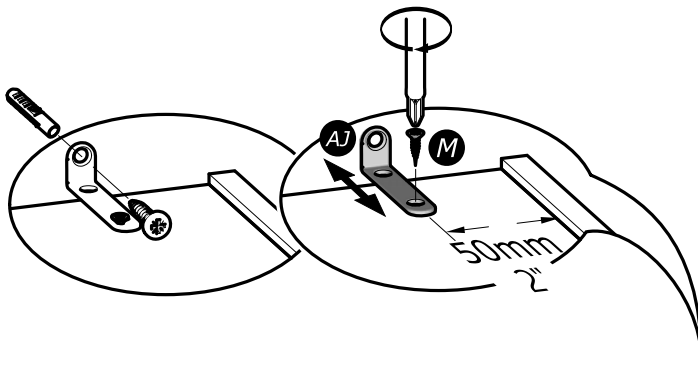
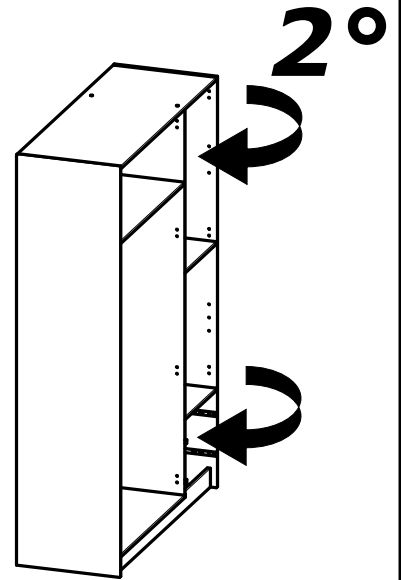
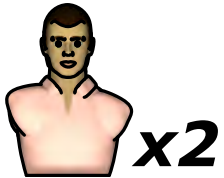
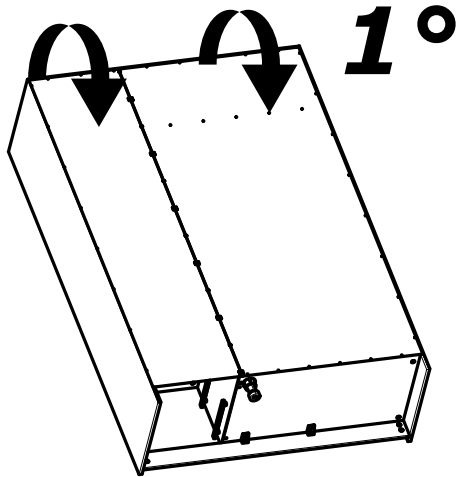
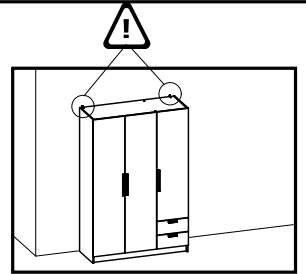
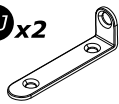

AJ + M

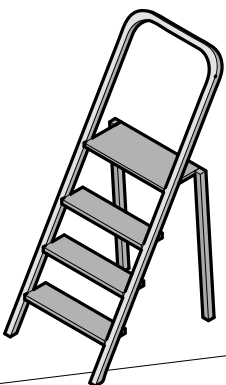
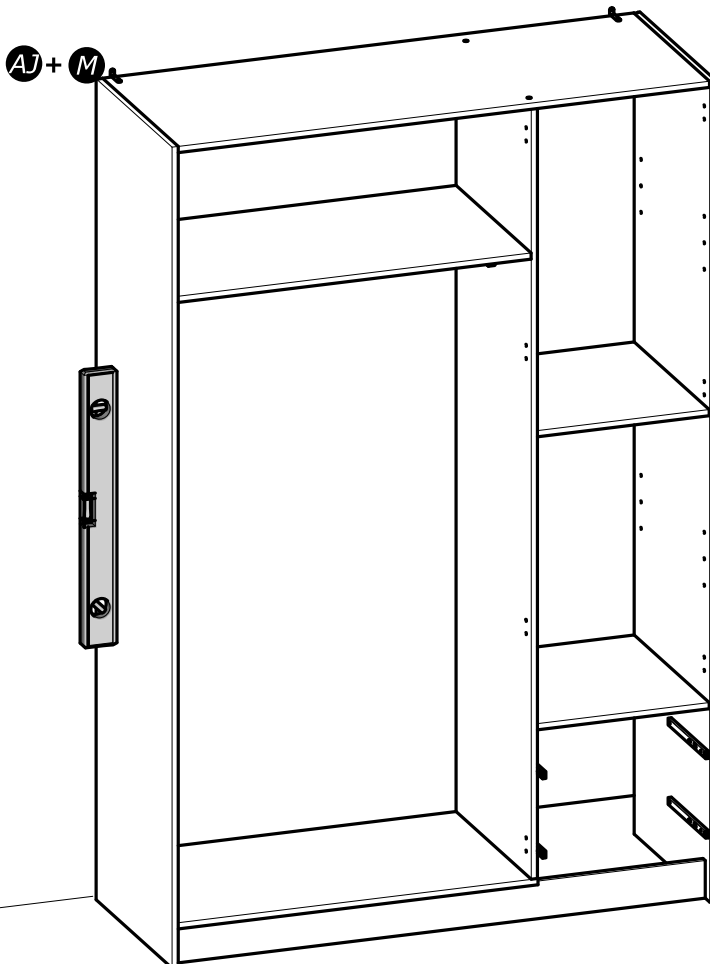

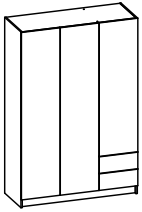

27

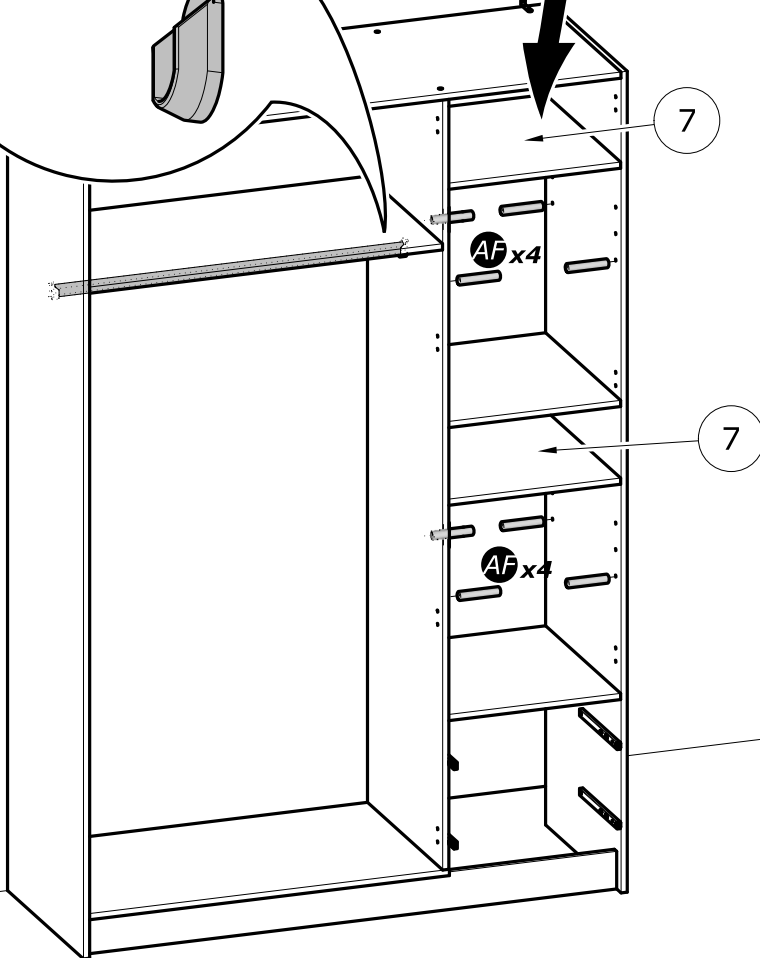
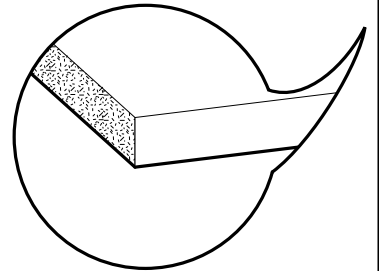
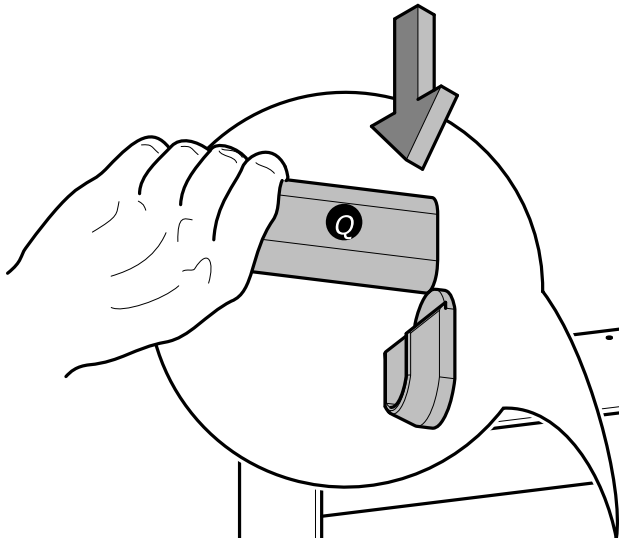
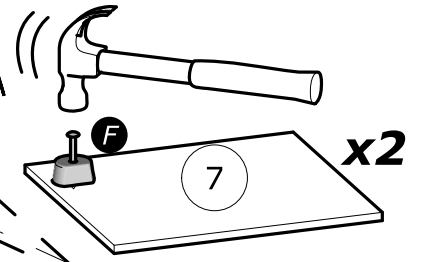
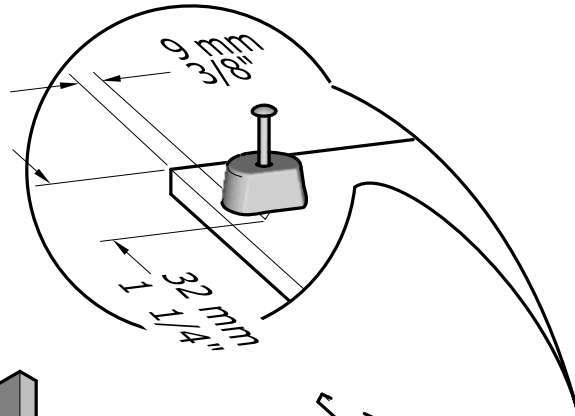
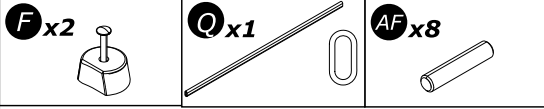

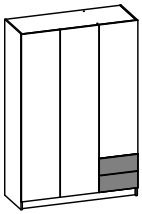

28

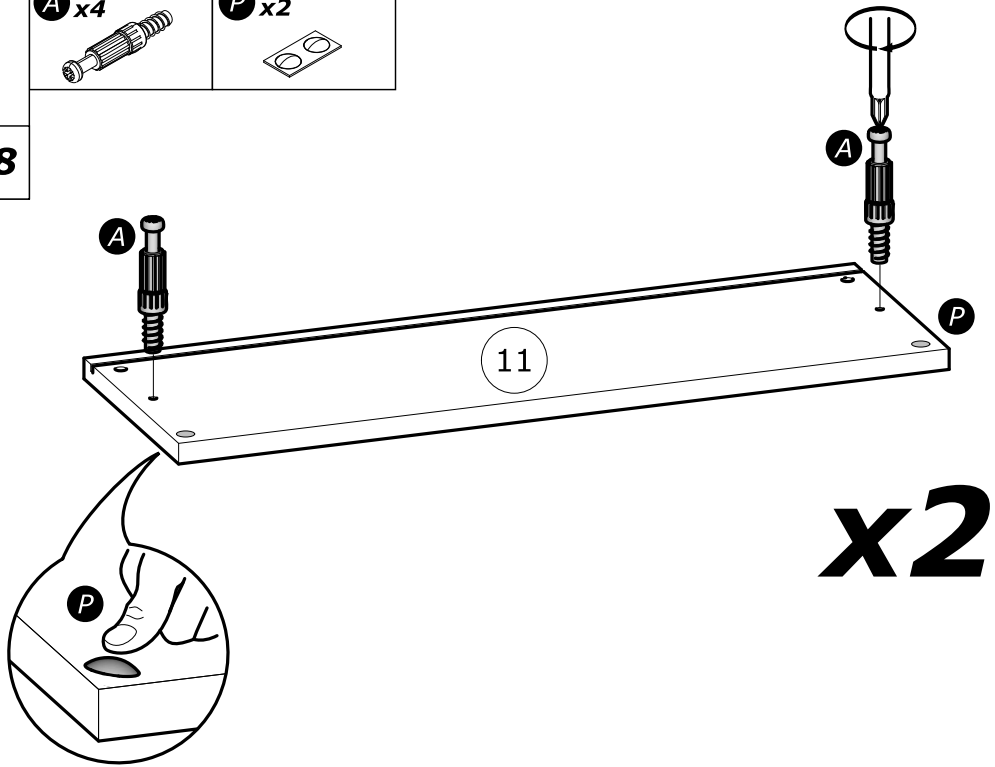
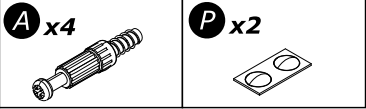

x2

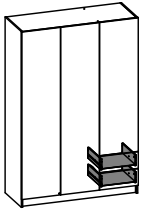

29

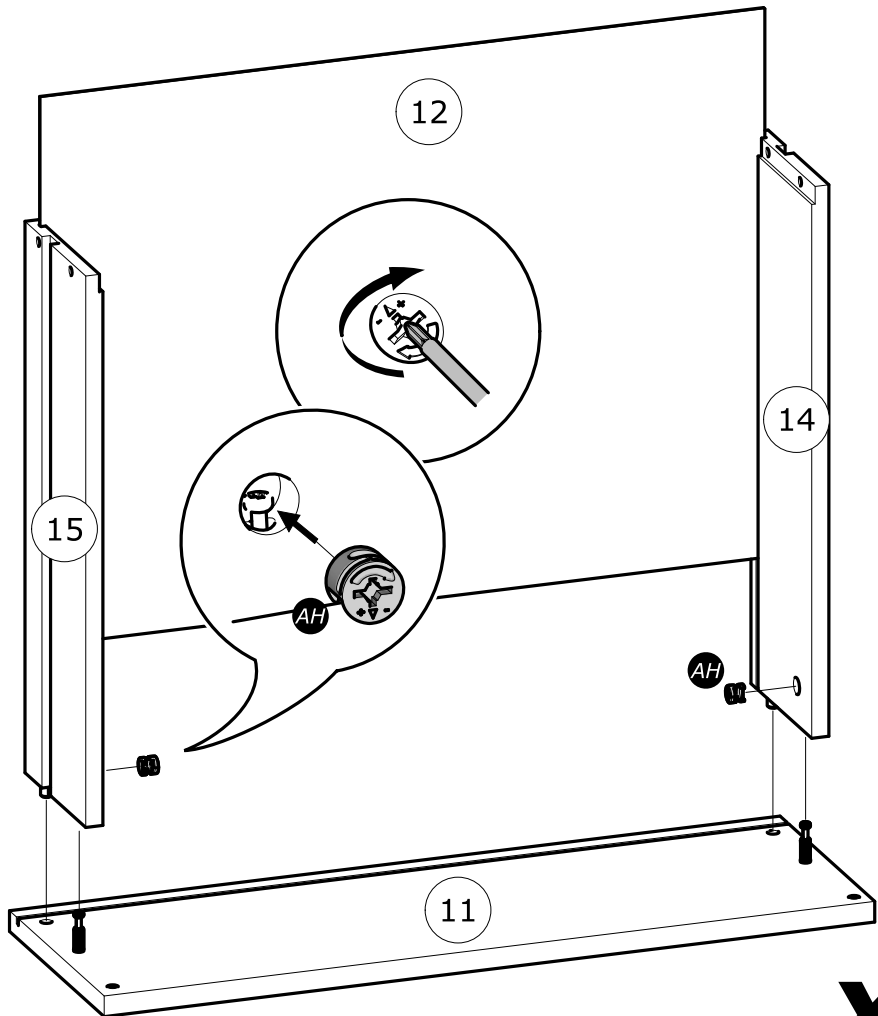
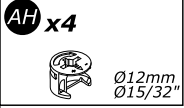

x2

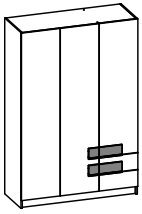

30

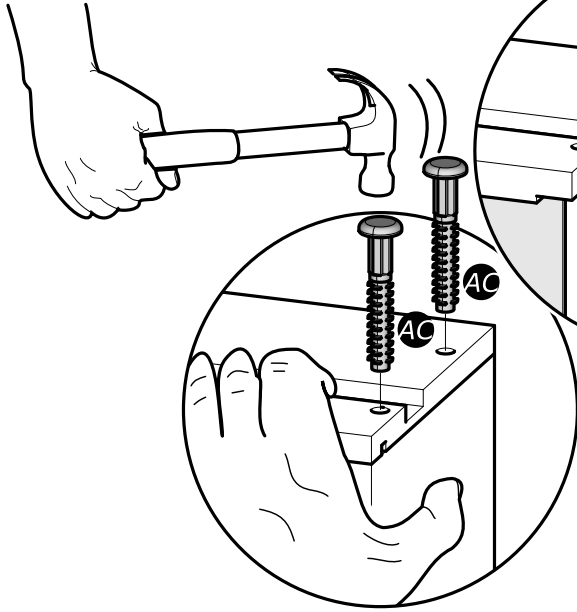
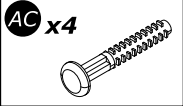

x2

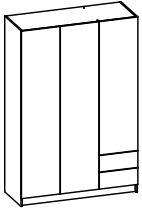
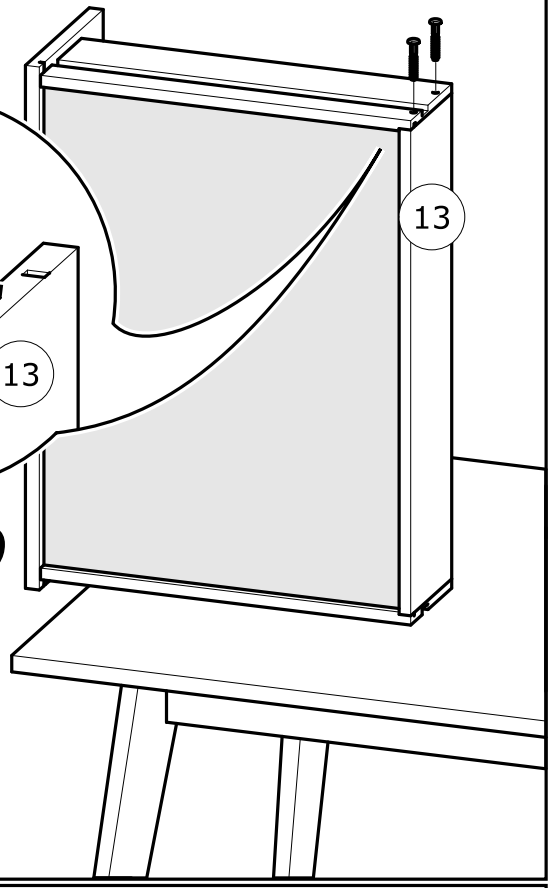

31

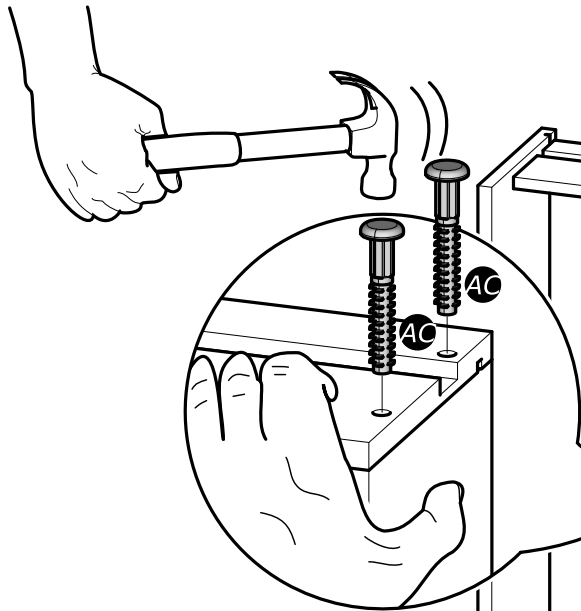
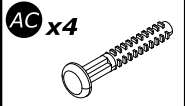

x2

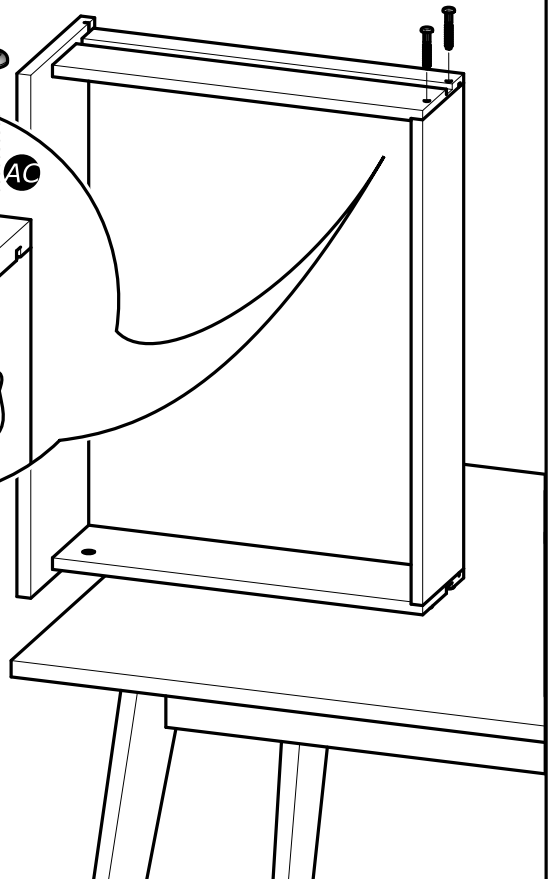
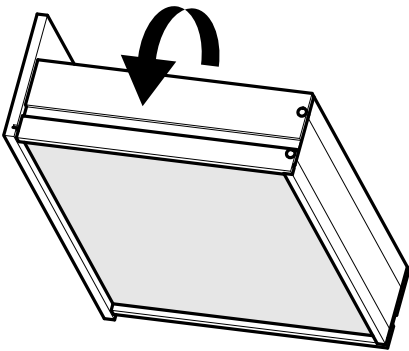



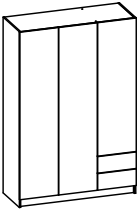

32

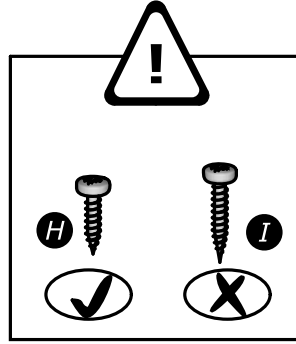
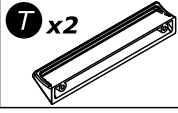
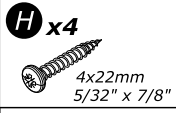

[www.Demeyere.fr](http://www.Demeyere.fr)

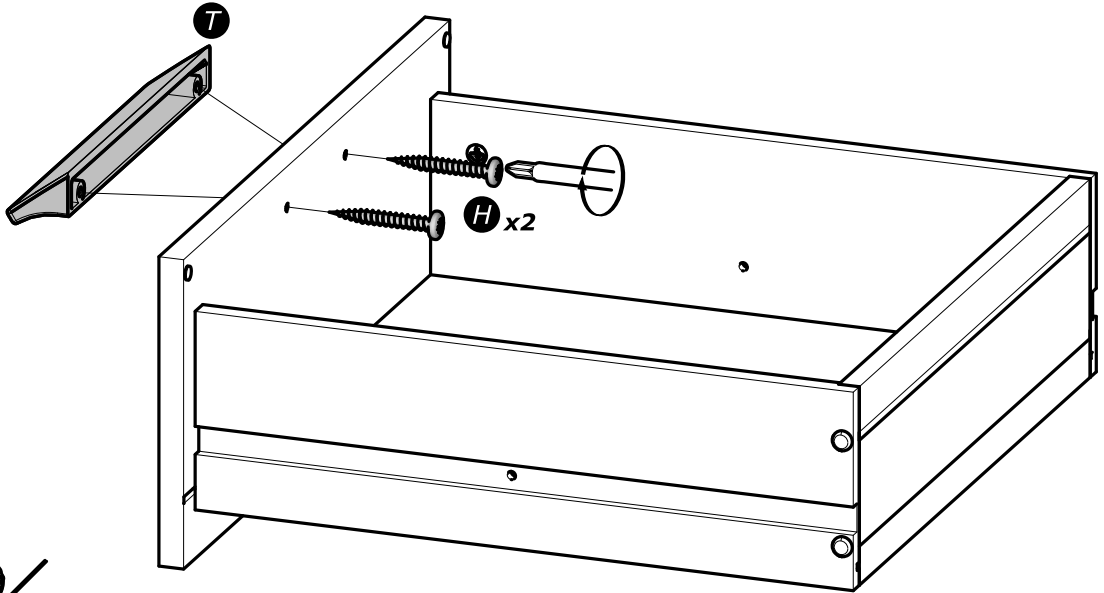

**x2**

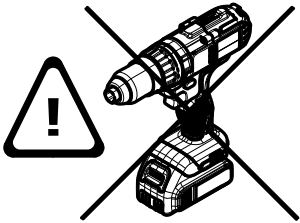



www.Demeyere.fr

**Ø x4**  
4x9mm  
5/32" x 11/32"

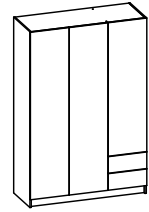

**33**

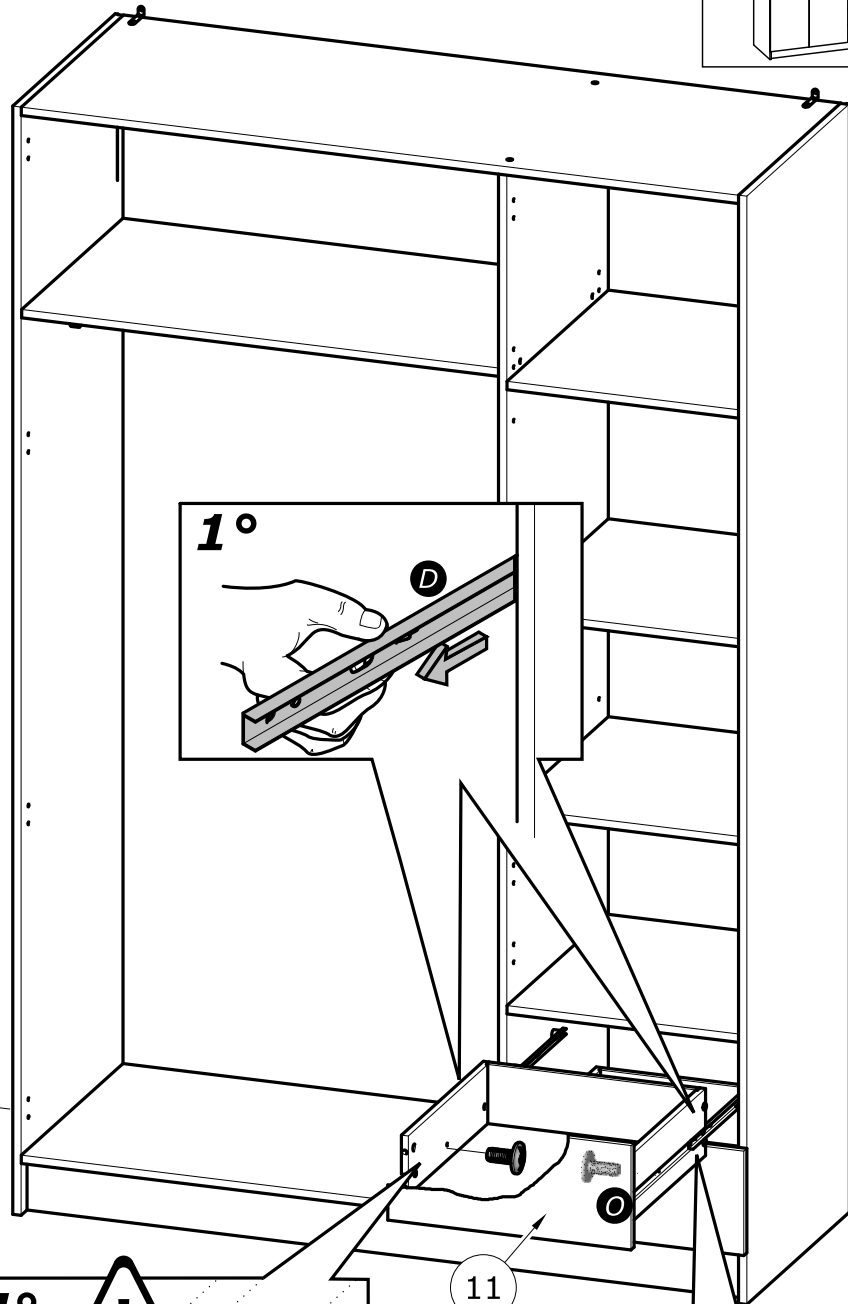

**x2**

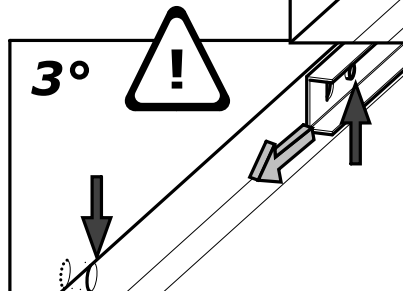
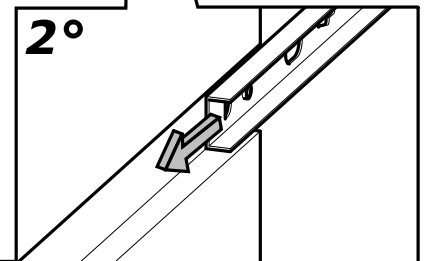
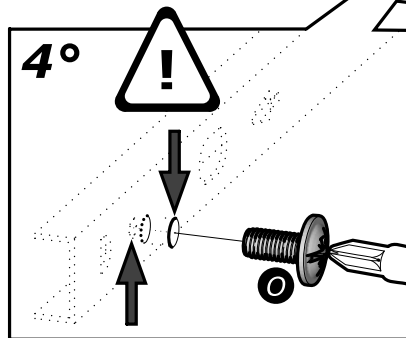

V x7

H=2mm  
H=1/16"

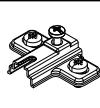

X x7

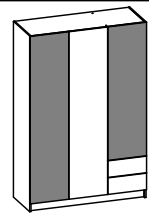
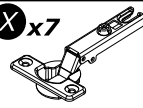

34

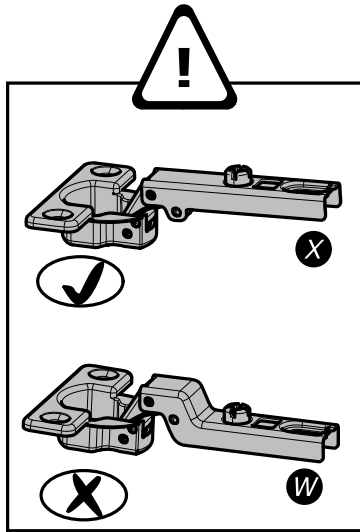
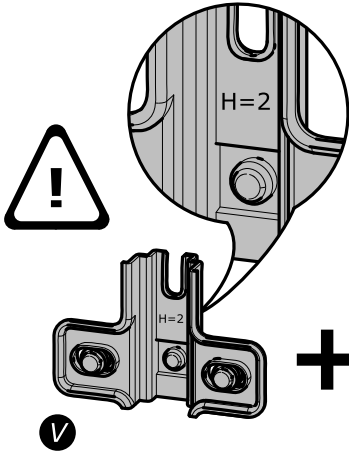

=

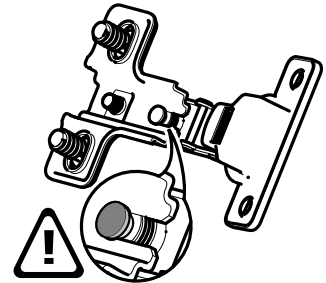
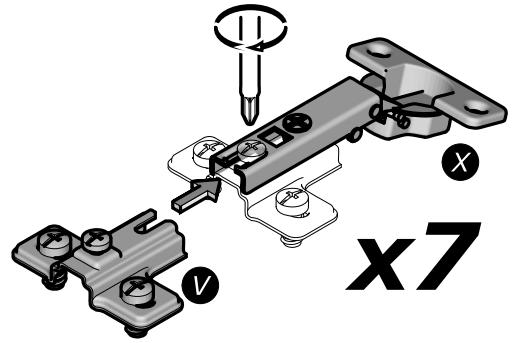

www.Demeyere.fr

M x8

3.5x15mm  
1/8" x 19/32"



P x1

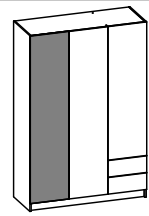

35

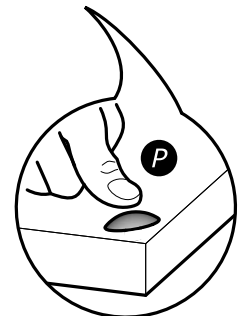
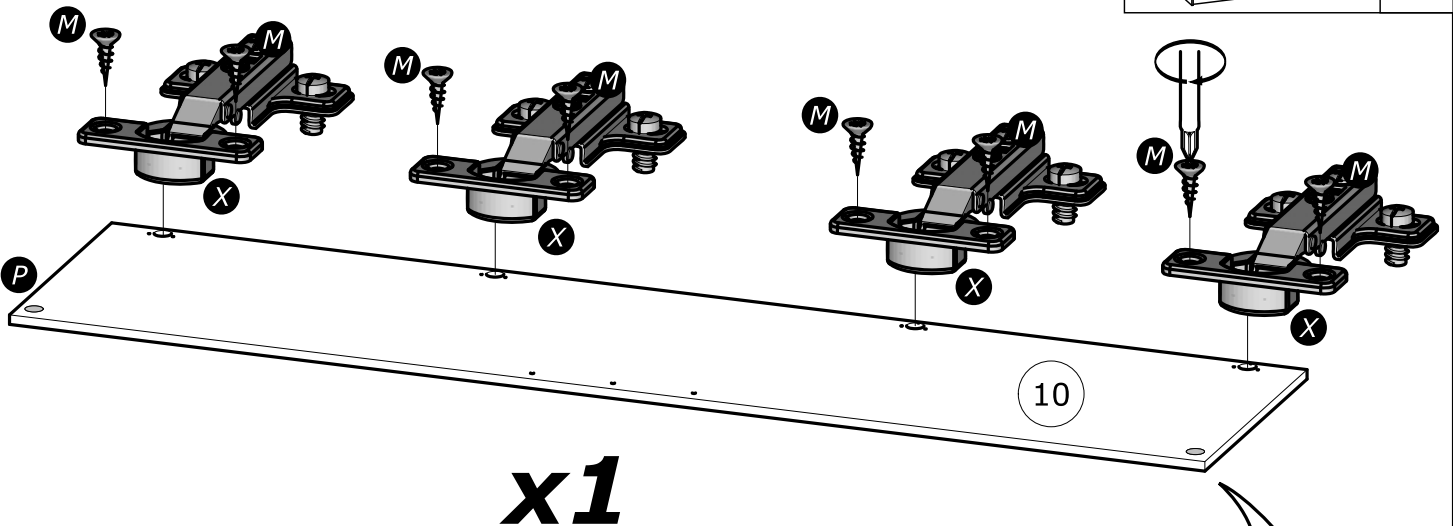

**M** x6  
3.5x15mm  
1/8" x 19/32"

**P** x1

**AA** x3

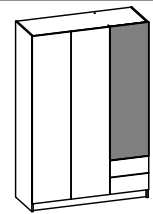

36

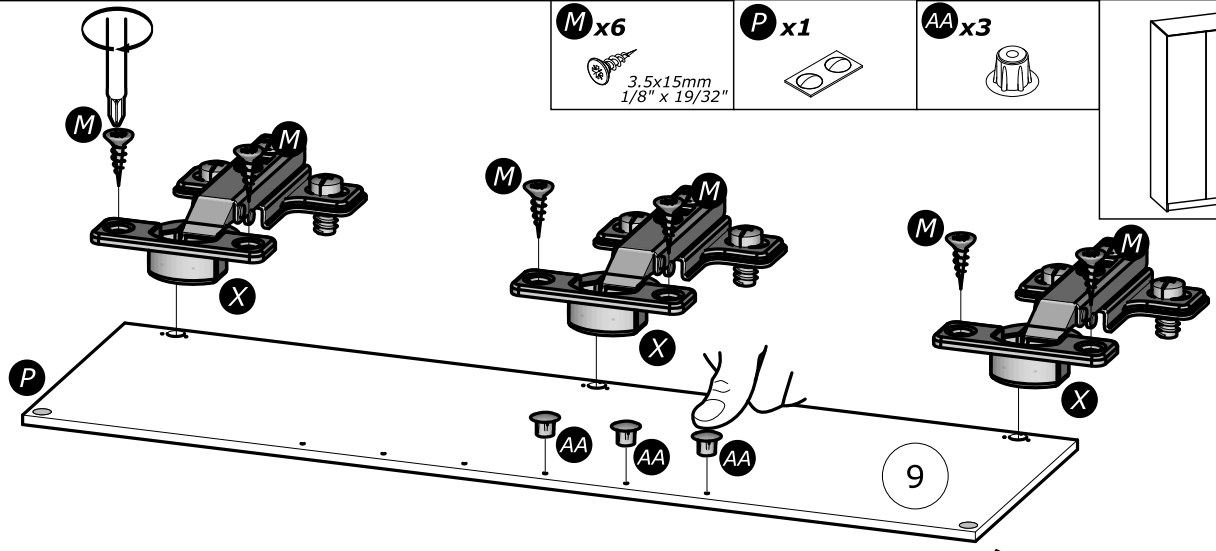

www.Demeyere.fr

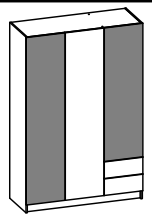
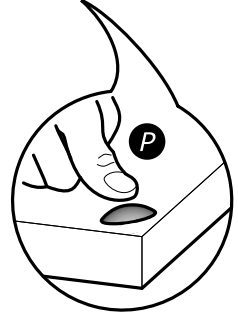

37

**I** x6  
4x25mm  
5/32" x 1"

**R** x2

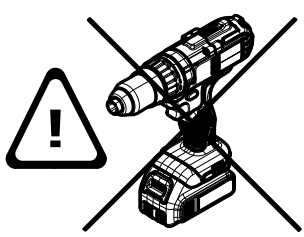
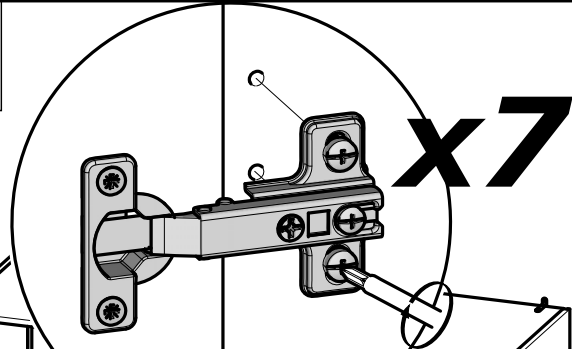

www.Demeyere.fr

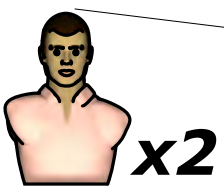
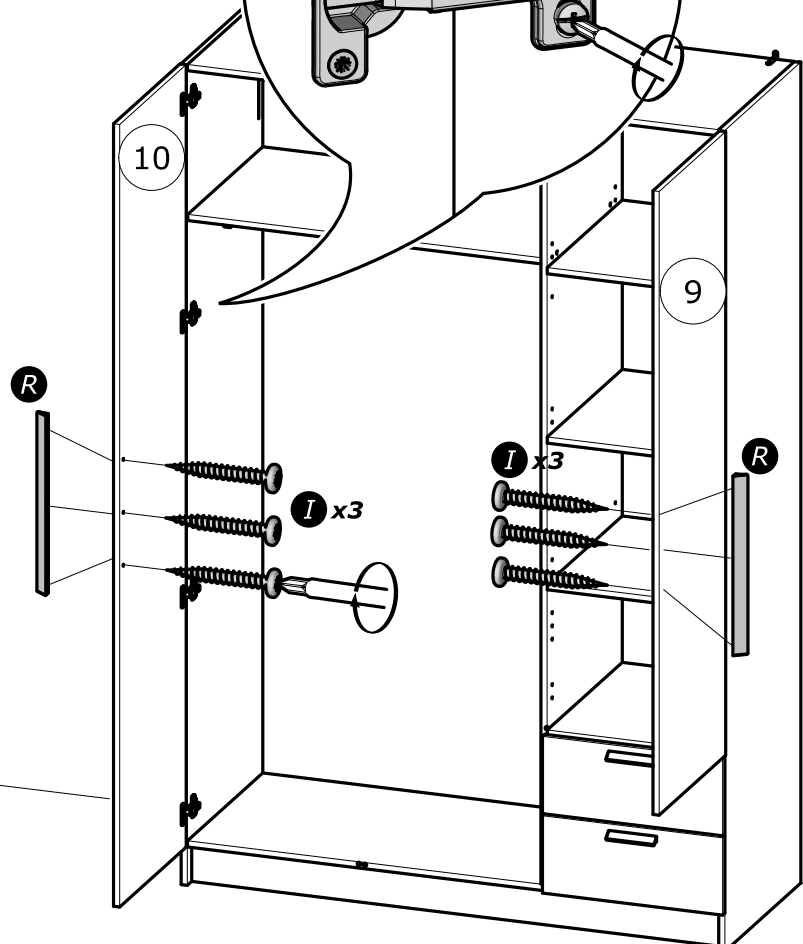

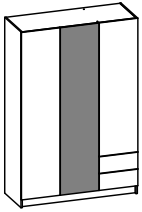

38

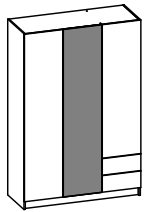
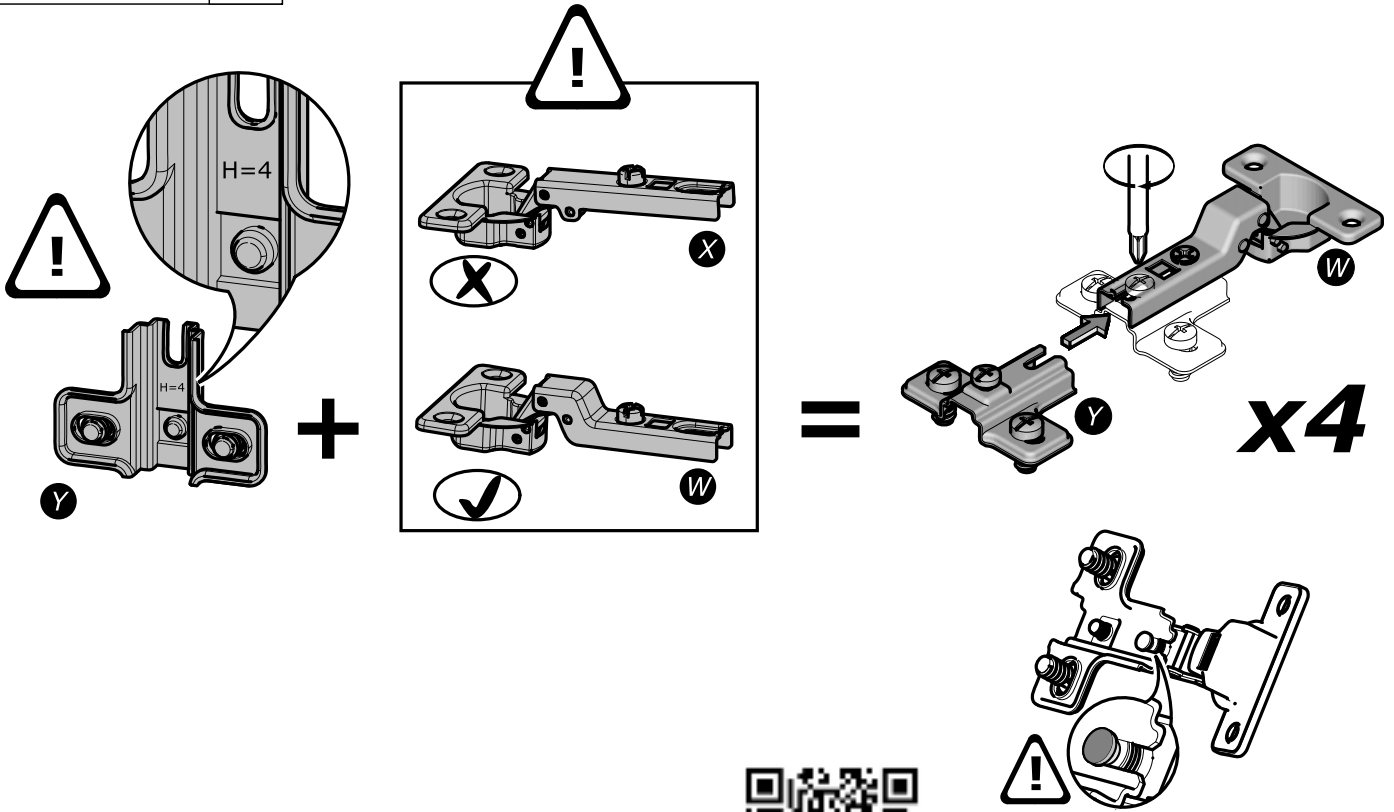
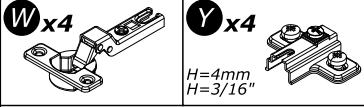

39

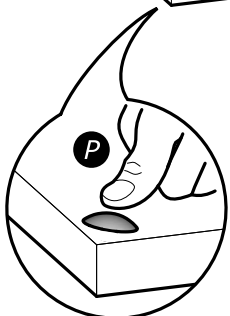
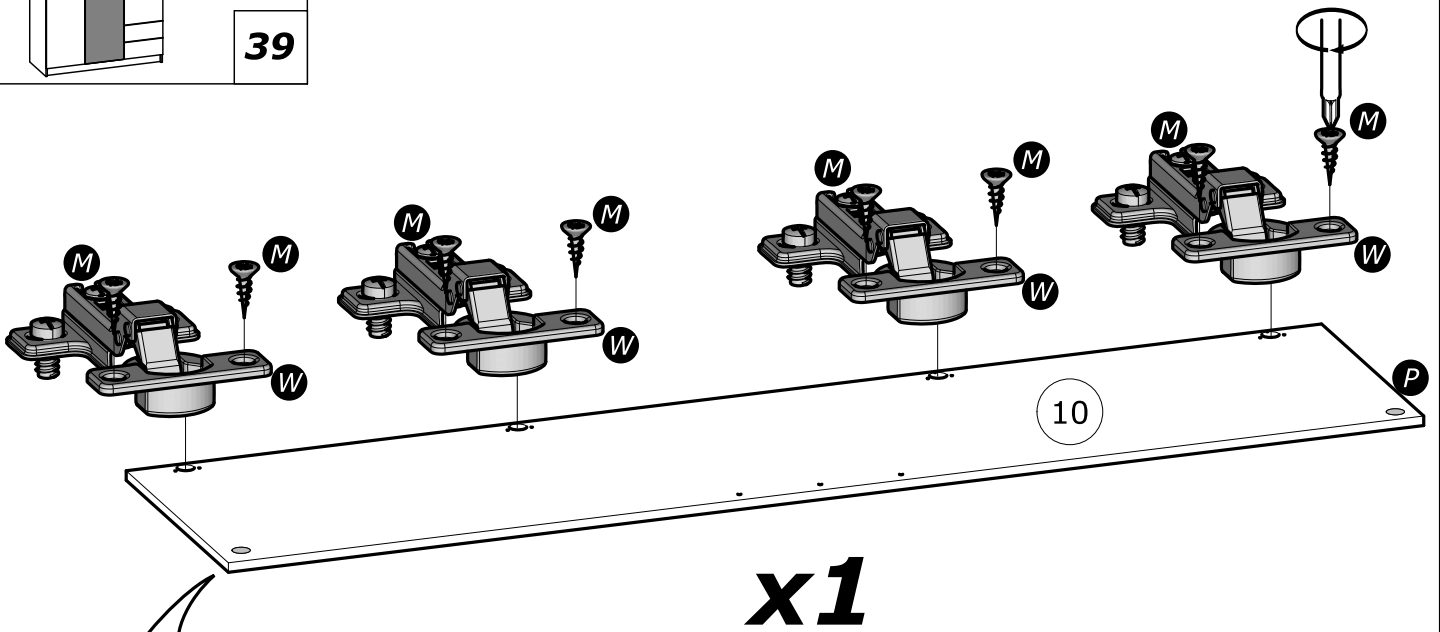
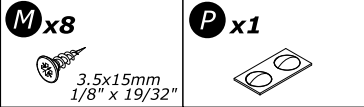

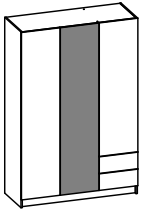

40

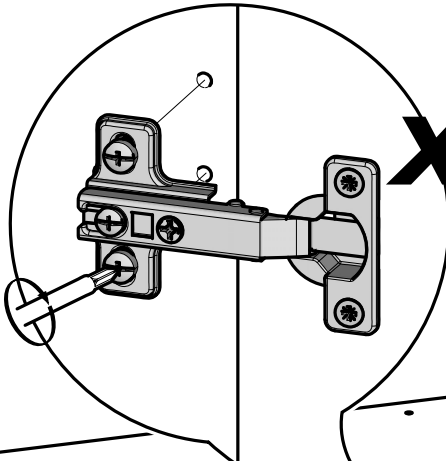
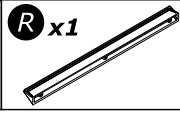
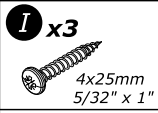

x4

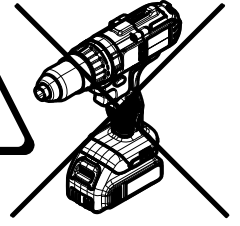

[www.Demeyere.fr](http://www.Demeyere.fr)

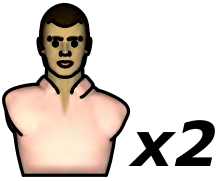
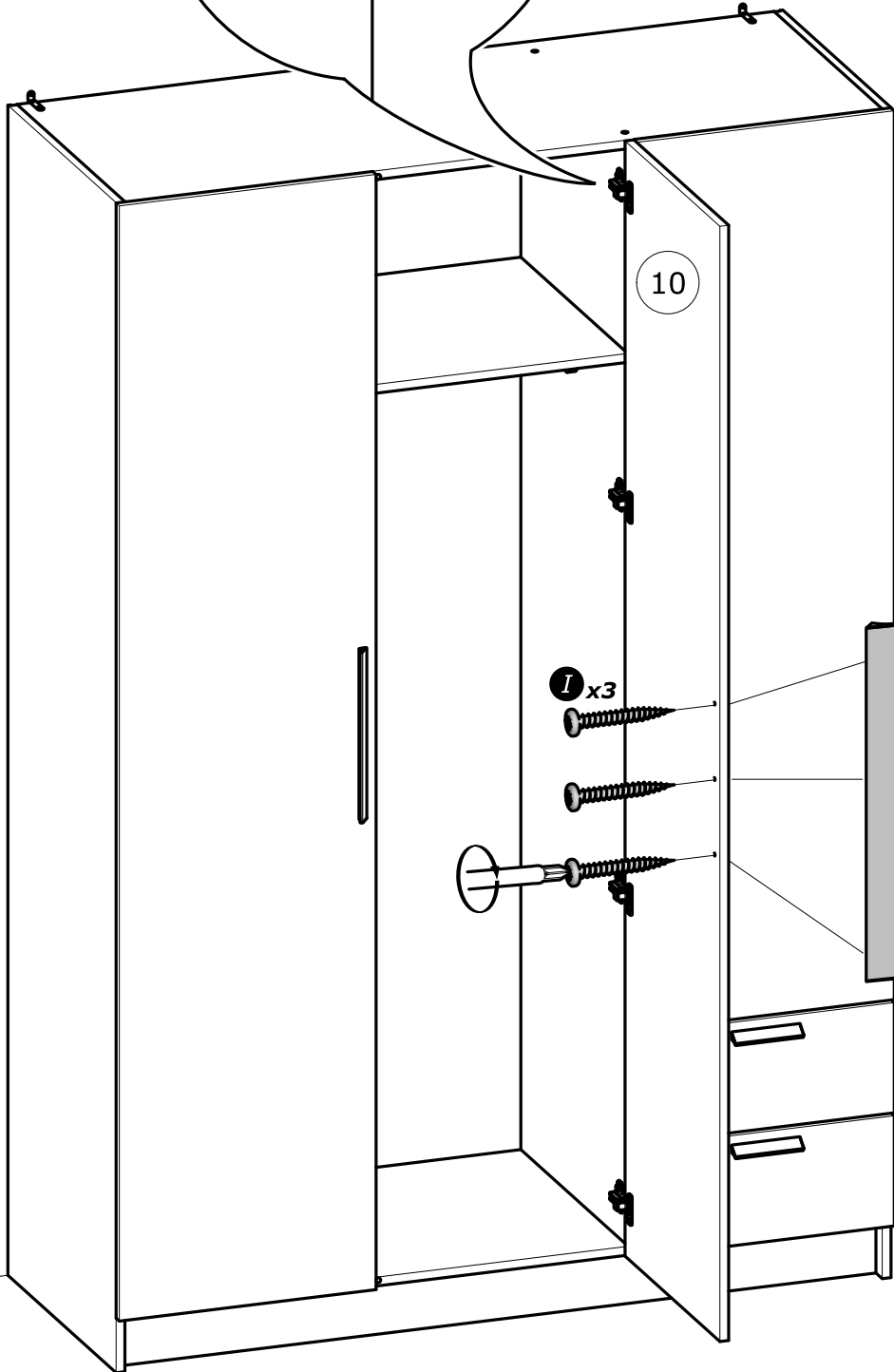

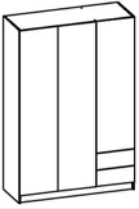

41



[www.Demeyere.fr](http://www.Demeyere.fr)

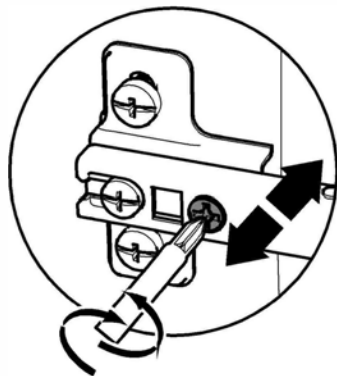
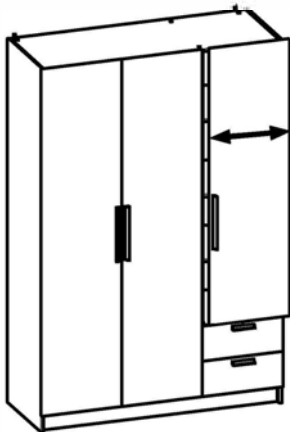
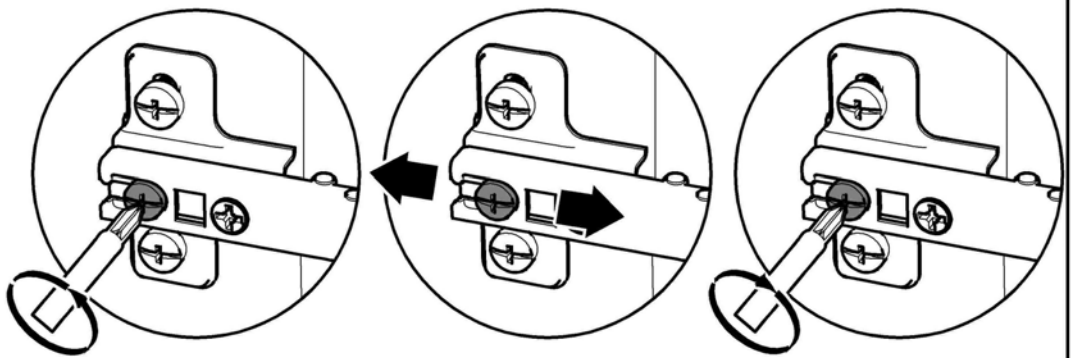
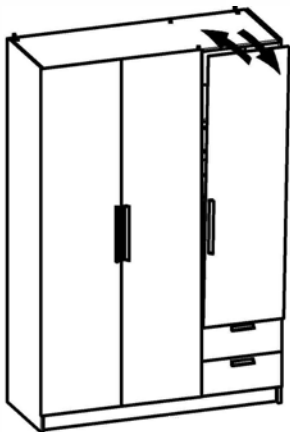
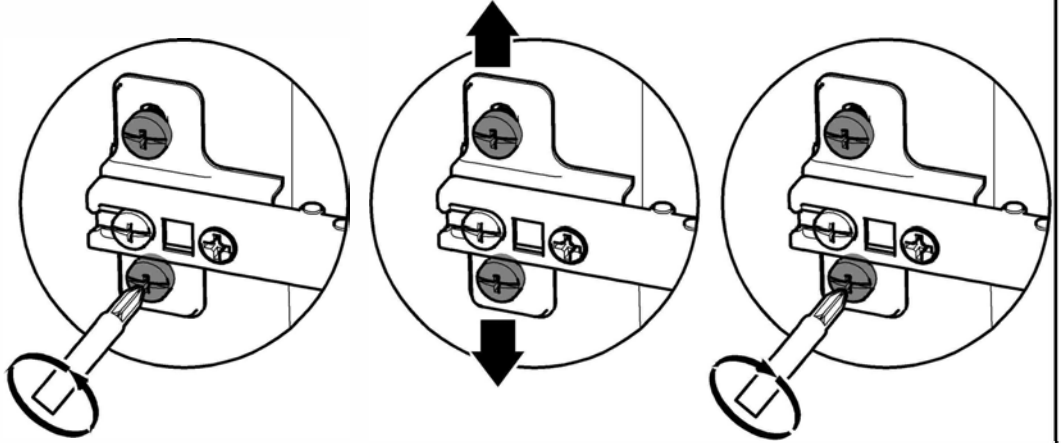
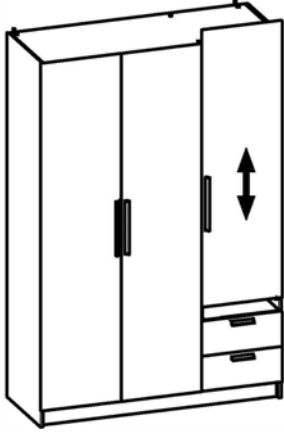

**Tříděte odpad**

Demeyere s.r.l. - Via S. Maria Maddalena, 1 - 36060 Montebelluna (TV) - Italy